

# XA235C-A1-101 Technical Specifications

## Contents

1 . Specifications .....	1
2 . Configuration .....	1
3 . Attachments .....	2
4 . First Test Condition (°C) .....	2
5 . Internal Protection Parts .....	2
6. Performance Data .....	3
7. Application Envelope .....	4
8. Drawing .....	4

## 1 . Specifications

Model	XA235C-A1-101	Power	8HP
Displacement(m <sup>3</sup> /h)	15.0	Refrigerant	R410A
Cooling Cap.(W) <sup>(a)</sup>	24032	Input Power(W) <sup>(a)</sup>	7502
Rated Load Amps(A) <sup>(a)</sup>	13.8	COP <sup>(a)</sup>	3.20
Max. Vibration(mm) <sup>(a)</sup>	<0.10	Sound Level (dBA) <sup>(a)</sup>	76
Test Power Source <sup>(a)</sup>	50Hz-380V	Rated Speed (RPM) <sup>(a)</sup>	2900
Max. Moisture (mg)	< 500	Max. Impurity (mg)	< 100
Oil Circulation (%) <sup>(a)</sup>	<1%	Weight (kg, With Oil)	53.0
Electrical Specification	Power Source	380V-420V 3~50Hz 460V 3~60Hz	
	Run Capacitor	/	
	Min. Operation Voltage(V) <sup>(b)</sup>	342	
	Max. Operation Voltage(V)	462	
	Min. Starting Voltage(V) <sup>(c)</sup>	323	
	Lock Rotor Amps(A)	100.00	
	Max. Operation Current <sup>(d)</sup>	18.6 (A)	
	Motor Insulation Temp.(°C)	130	
Terminal Resistance (Ω) ( ± 10%) At 25 °C	T1(C)-T2(S)	1.34	
	T2(S)-T3(R)	1.26	
	T3(R)-T1(C)	1.31	
Lubrication	Oil Type	POE	
	Initial Charge(L)	3.5	
	Recharge(L)	3.0	
Electrical Safety	Insulation Voltage(V)	2500	
	Leakage Current(mA)	≤5	
	Insulation Resistance(MΩ)	>20	
	Ground Resistance(Ω)	<0.1	
Max. Operation Pressure	High Side(MPa)	4.3	
	Low Side(MPa)	2.0	

Notes:

- a) Test Condition: Based On Test Power Voltage, First Rated Condition;
- b) Test Condition: ET 13°C, CT 65°C, SH 11.1K
- c) Test Condition: Discharge/Suction Pressure Set To Refrigeration Saturation Pressure At 40°C.
- d) Test Condition: ET 13°C, CT 65°C, SH11.1K, 90% Min. Rated Voltage;

## 2 . Configuration

Suction/Discharge	Injection	Sight Glass	Thermal Tube
Welded Fittings	NONE	Screw Sight Glass	NONE

## 3 . Certifications

Certifications	Report N.O.
CB	CNCVC1150-A1
CE	LVDJX23-0057
CCC	CVC23008010772
PED	/
UL	/

## 4 . First Test Condition (°C)

Cooling Cap. and COP No Less Than **95%** of Nominal Value, Power and Current No More Than 105% of Nominal Value (Performance And Sound Power Need 24hrs Break In At High Load Running Condition)。

Item	Parameter	Value
1	Evaporating Temp.	7.2
2	Condensing Temp.	54.4
3	Ambient Temp.	35.0
4	Super Heat	11.1
5	Sub Cooling	8.3

## 5 . Compressor Protection Parts

- a) Thermal Protection Inside:37HM546-20;
- b) Internal Pressure Release Valve, Open Range (Pressure Difference Between Discharge And Suction) : 3.96~4.31Mpa

**6. Performance Data- XA235C-A1-101**

kW	Temp. Cond.( °C)	Temp. Evap. (°C)								
		-25	-20	-15	-10	-5	0	5	10	13
Cooling Cap.	65						14.95	18.17	21.93	24.55
	60					13.72	16.75	20.21	24.26	27.09
	55				12.28	15.15	18.36	22.02	26.33	29.35
	50			10.70	13.42	16.42	19.78	23.63	28.19	31.41
	45		9.06	11.63	14.45	17.57	21.06	25.09	29.90	33.33
	40	7.43	9.83	12.48	15.40	18.63	22.26	26.48	31.57	35.21
	35	8.08	10.56	13.30	16.32	19.66	23.45	27.89	33.29	37.20
	30	8.72	11.29	14.13	17.25	20.74	24.72	29.42	35.21	39.42
	25	9.40	12.06	15.01	18.27	21.94	26.16	31.20	37.46	42.04
Input Power	65						10.05	9.93	9.85	9.82
	60					8.91	8.78	8.69	8.62	8.60
	55				7.94	7.82	7.71	7.64	7.59	7.58
	50			7.12	7.00	6.89	6.81	6.76	6.73	6.73
	45		6.41	6.29	6.19	6.11	6.05	6.01	6.00	6.01
	40	5.76	5.66	5.58	5.50	5.44	5.40	5.38	5.38	5.40
	35	5.08	5.01	4.95	4.90	4.86	4.84	4.83	4.84	4.86
	30	4.46	4.42	4.38	4.35	4.33	4.33	4.33	4.36	4.38
	25	3.88	3.86	3.85	3.84	3.83	3.84	3.86	3.90	3.93

Notes: Capacity Calculation Based On SH=11.1K,SC=8.3K

### 7. Application Envelope

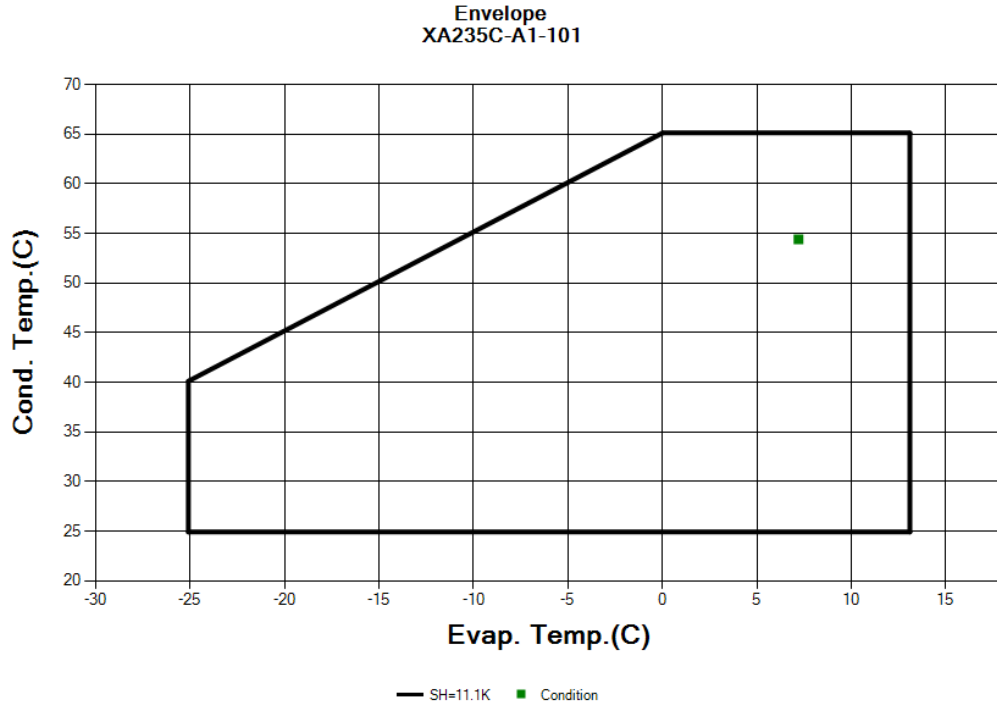

For Compressor Safty, Shutdown Compressor When DLT Above 125°C; When Compressor Running, Control DLT<= 110°C ;ReStart Compressor When DLT Below 85°C

### 8. Drawing



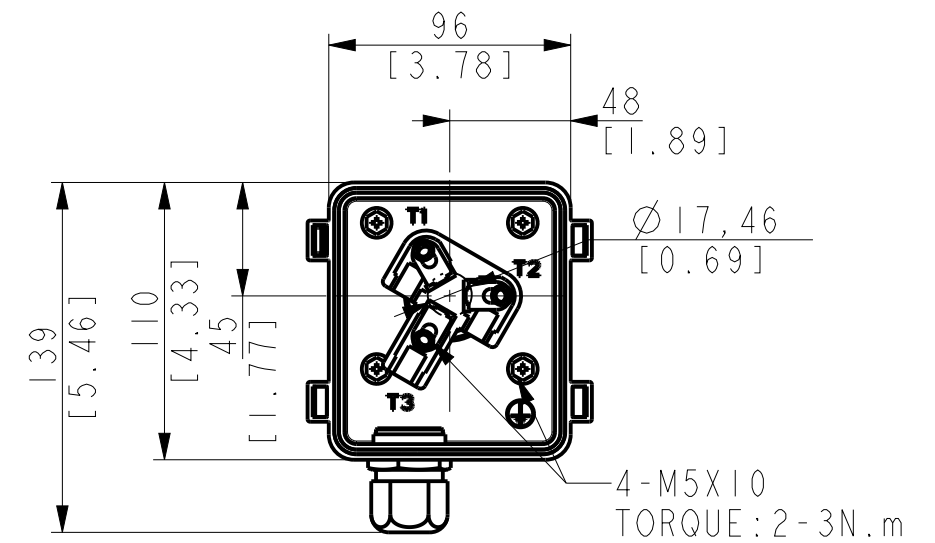
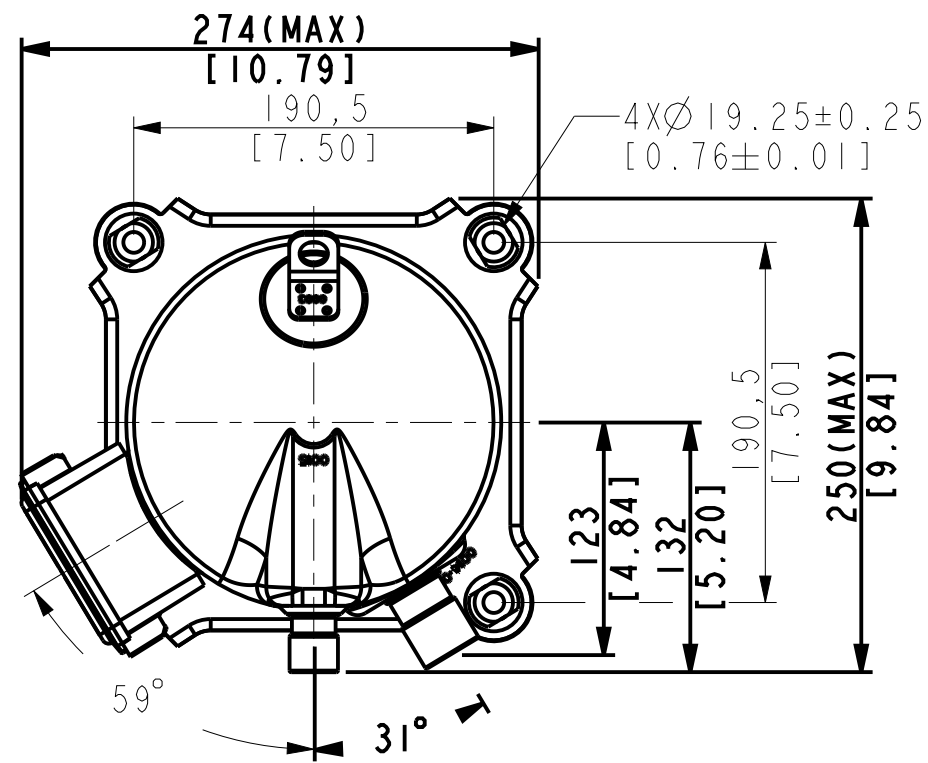

TERMINAL BOX LAYOUT  
SCALE 1:3

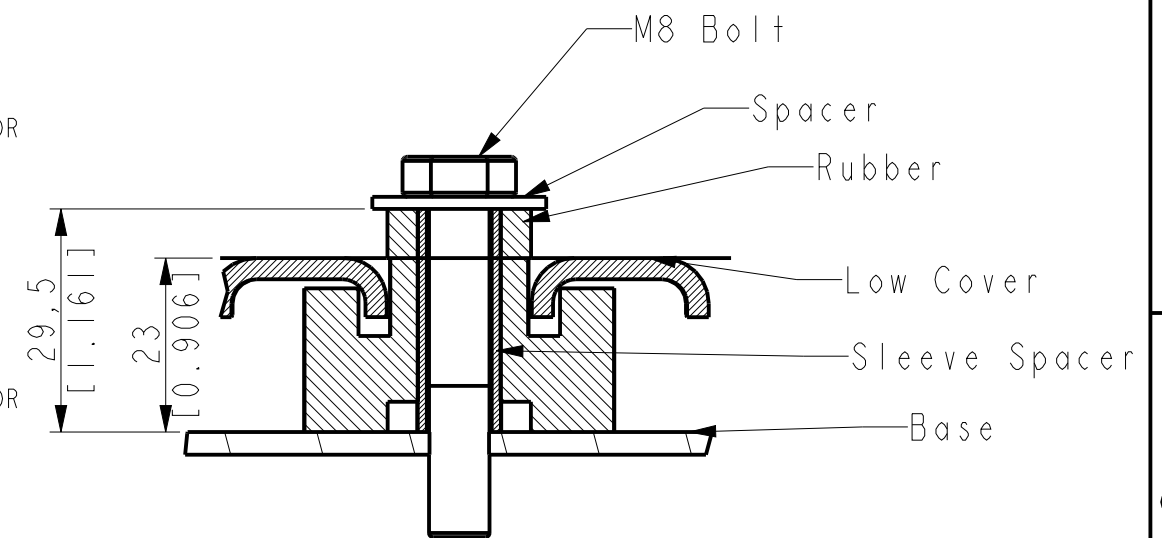
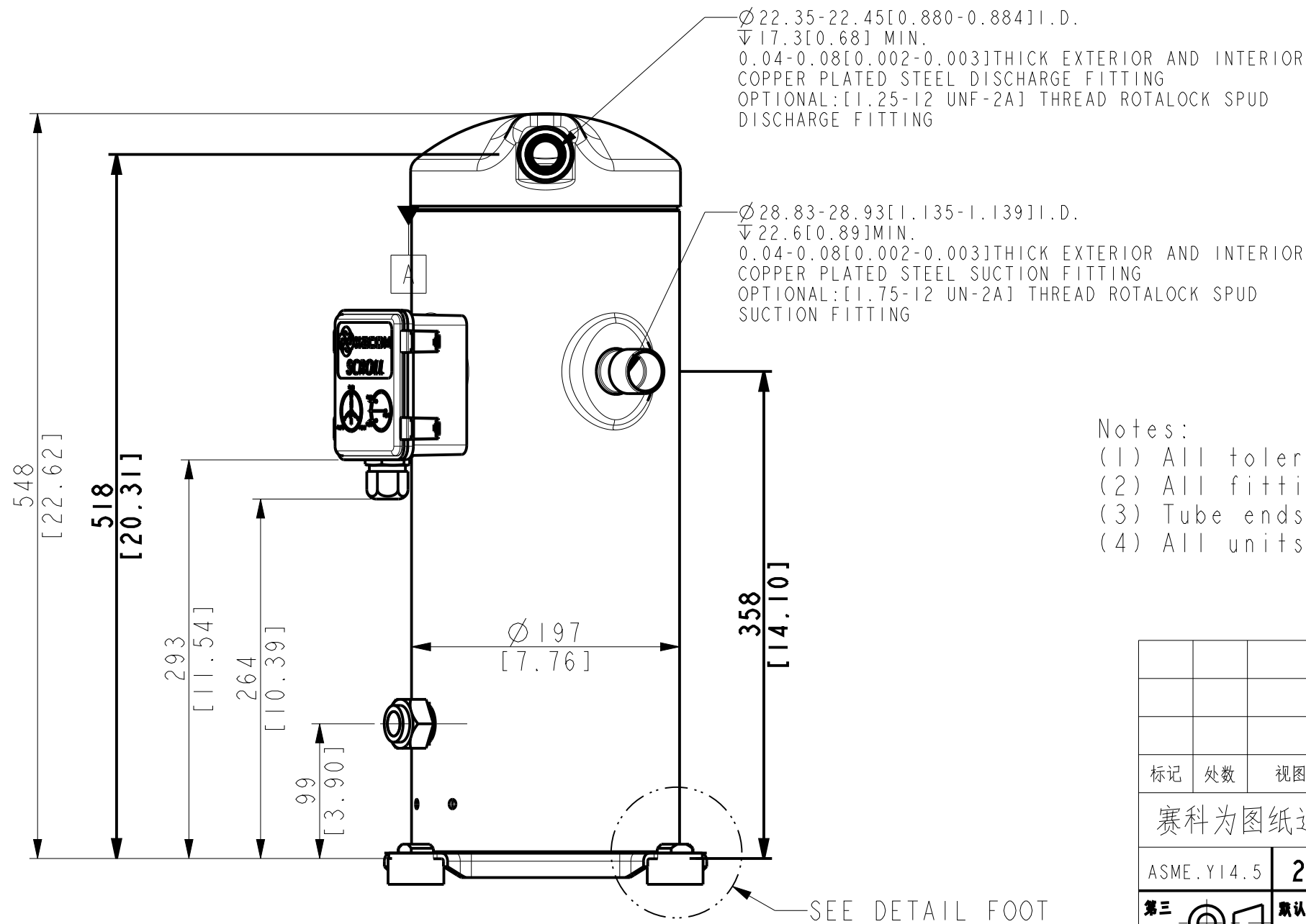

DETAIL FOOT

- Notes:
- (1) All tolerances 1.5mm [0.06in] unless otherwise specified
  - (2) All fittings: + 3.0mm 0.12in
  - (3) Tube ends must be plugged
  - (4) All units are in mmlinch]

						常州赛科为能源科技有限公司 Xecom Energy Technologies Ltd.		
标记	处数	视图	ECN代码	签字	日期	190外形图 (XR)		
赛科为图纸通用标准						版本标记	重量	比例
ASME.Y14.5						0	0,333	801-0003-02EN
第三 视角	默认 公差		X ±0.4 X.X ±0.15 X.XX ±0.15 角尺: ±0.5°	校对	批准	共 1 张 第 1 张		

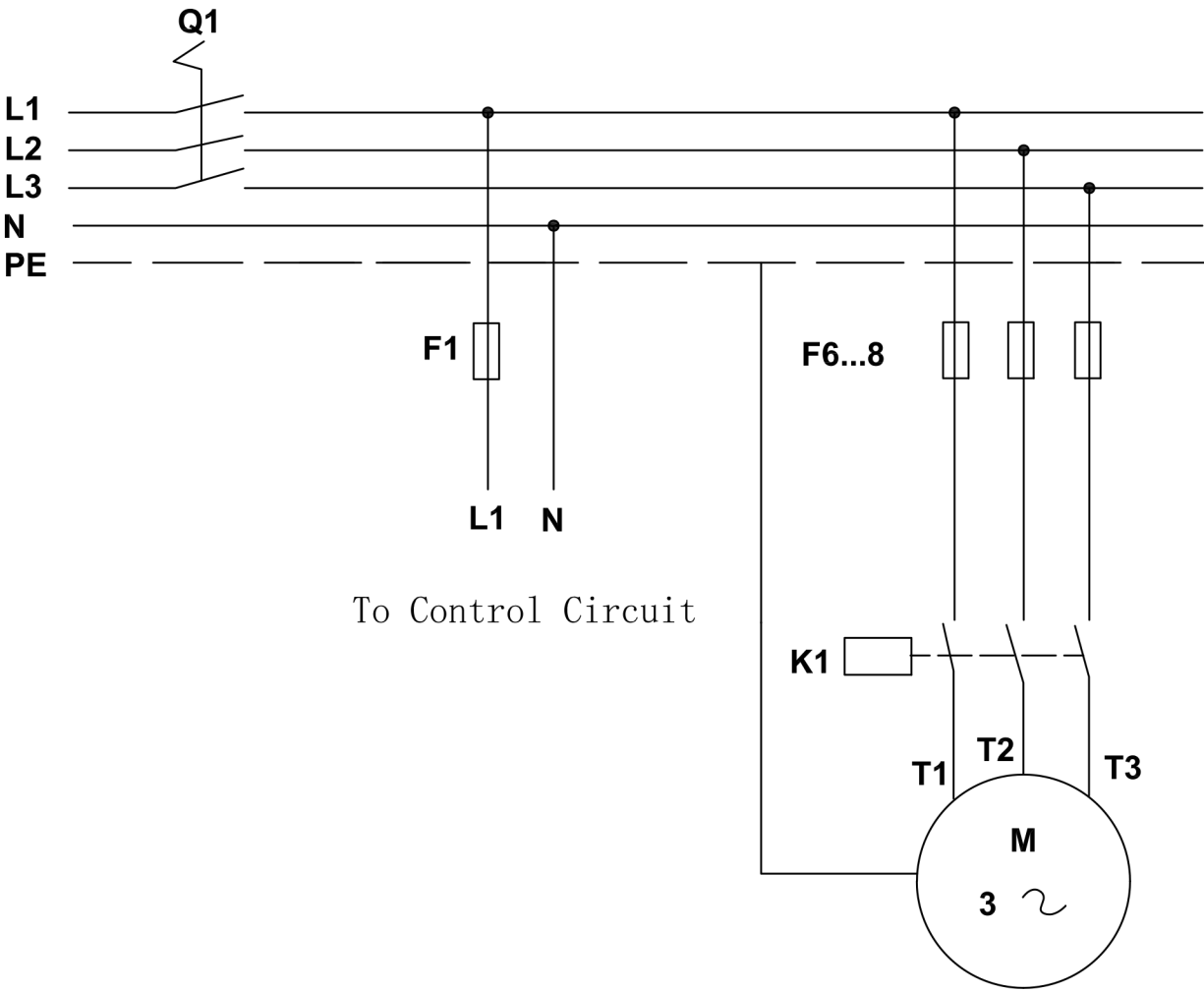

Electrical Schematics

L1/L2/L3/N/PE: 3 Phase Lines(line/neutral/ground)



- Q1: Manual Switch
- F1/F6...8: Fuse
- K1: Compressor Contactor
- M: Compressor Motor
- T1/T2/T3: Compressor Terminal

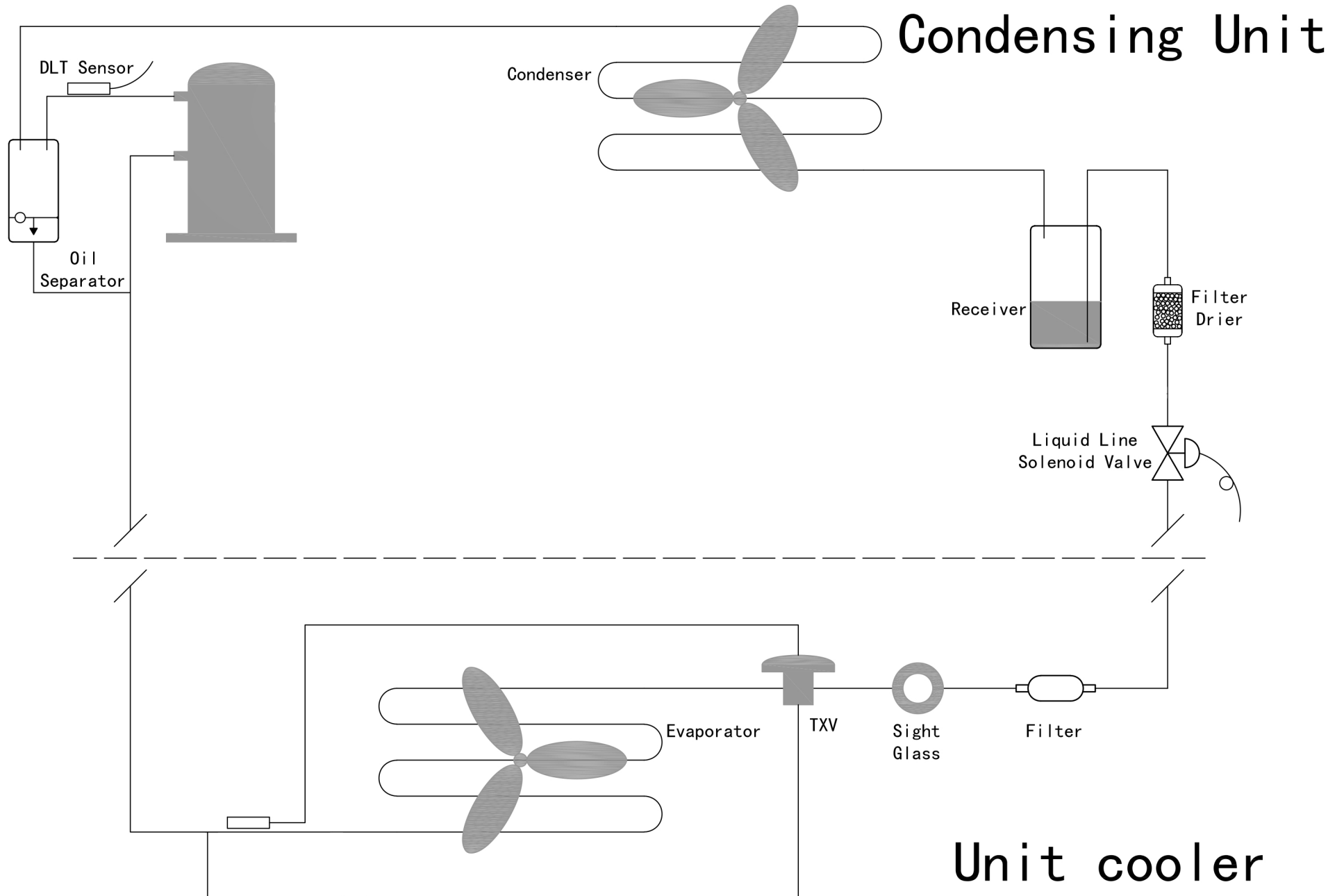

# General System Schematic







附件列表  
Accessories List

Part N.O.	Specification	Qty	Part Name	Picture	Type	Description
019-0002-00	11.1*29.5	Sleeve Spacer		4	Standard	
200-0001-00		Rubber		4	Standard	
100-0006-00	M5x8,GB/T5789	Bolt		7	Standard	



附件列表  
**Accessories List**

034-0003-03		Sound Jacket		1	Optional	
028-0003-00	197 外壳 90W 220V, 长度 618.6	Crank Heater		1	Optional	
017-0001-00		Terminal Box		1	Standard	
009-0025-00		Terminal Cover Seal		1	Standard	
009-0023-00		Terminal Seal		1	Standard	

附件列表  
**Accessories List**

016-0003-00		T-Box		1	Standard	
017-0002-00		Terninal Cover		1	Standard	
031-0015-00		Oil Adapter		1	Optional	
033-0005-00	OUT580R/GOA114	Oil Regulator		1	Optional	
031-0017-00	螺纹 1-1/4"- 12UNF-A	RotoLock Connector		1	Optional	

附件列表  
**Accessories List**

031-0018-00	1 3/4-12UNF 2A 螺纹口	RotoLock Connector		1	Optional	
030-0000-00	1-1/4"-12UNF	Sight glasses		1	Standard	
200-0002-00		Steel		4	Optional	