

XA625A-A1-101 Technical Specifications

Contents

1 . Specifications	1
2 . Configuration	1
3 . Attachments	2
4 . First Test Condition (°C)	2
5 . Internal Protection Parts	2
6. Performance Data	3
7. Application Envelope	4
8. Drawing	4

1 . Specifications

Model	XA625A-A1-101	Power	20HP
Displacement(m ³ /h)	58.1	Refrigerant	R22
Cooling Cap.(W) ^(a)	61592	Input Power(W) ^(a)	17758
Rated Load Amps(A) ^(a)	34.8	COP ^(a)	3.47
Max. Vibration(mm) ^(a)	<0.10	Sound Level (dBA) ^(a)	79
Test Power Source ^(a)	50Hz-380V	Rated Speed (RPM) ^(a)	2900
Max. Moisture (mg)	< 500	Max. Impurity (mg)	< 100
Oil Circulation (%) ^(a)	<1%	Weight (kg, With Oil)	109.0
Electrical Specification	Power Source	380V-420V 3~50Hz 460V 3~60Hz	
	Run Capacitor	/	
	Min. Operation Voltage(V) ^(b)	342	
	Max. Operation Voltage(V)	462	
	Min. Starting Voltage(V) ^(c)	323	
	Lock Rotor Amps(A)	266.00	
	Max. Operation Current ^(d)	45.7 (A)	
	Motor Insulation Temp.(°C)	130	
Terminal Resistance (Ω) (± 10%) At 25 °C	T1(C)-T2(S)	0.51	
	T2(S)-T3(R)	0.51	
	T3(R)-T1(C)	0.50	
Lubrication	Oil Type	3GS	
	Initial Charge(L)	6	
	Recharge(L)	5.6	
Electrical Safety	Insulation Voltage(V)	2500	
	Leakage Current(mA)	≤5	
	Insulation Resistance(MΩ)	>20	
	Ground Resistance(Ω)	<0.1	
Max. Operation Pressure	High Side(MPa)	3.0	
	Low Side(MPa)	2.0	

Notes:

- a) Test Condition: Based On Test Power Voltage, First Rated Condition;
- b) Test Condition: ET 13°C, CT 65°C, SH 11.1K
- c) Test Condition: Discharge/Suction Pressure Set To Refrigeration Saturation Pressure At 40°C.
- d) Test Condition: ET 13°C, CT 65°C, SH11.1K, 90% Min. Rated Voltage;

2 . Configuration

Suction/Discharge	Injection	Sight Glass	Thermal Tube
Welded Fittings	NONE	Screw Sight Glass	NONE

3 . Certifications

Certifications	Report N.O.
CB	/
CE	/
CCC	/
PED	/
UL	/

4 . First Test Condition (°C)

Cooling Cap. and COP No Less Than **95%** of Nominal Value, Power and Current No More Than 105% of Nominal Value (Performance And Sound Power Need 24hrs Break In At High Load Running Condition)。

Item	Parameter	Value
1	Evaporating Temp.	7.2
2	Condensing Temp.	54.4
3	Ambient Temp.	35.0
4	Super Heat	11.1
5	Sub Cooling	8.3

5 . Compressor Protection Parts

- a) Thermal Protection Outside:522-0001-00;
- b) Internal Pressure Release Valve, Open Range (Pressure Difference Between Discharge And Suction) : 2.76~3.10Mpa

6. Performance Data- XA625A-A1-101

kW	Temp. Cond.(°C)	Temp. Evap. (°C)								
		-25	-20	-15	-10	-5	0	5	10	13
Cooling Cap.	65						41.00	49.60	59.40	65.95
	60					36.14	44.11	53.18	63.52	70.43
	55				31.37	38.71	47.07	56.58	67.42	74.67
	50			26.79	33.50	41.16	49.88	59.80	71.11	78.69
	45		22.47	28.54	35.52	43.49	52.54	62.84	74.61	82.49
	40	18.49	23.93	30.23	37.47	45.71	55.08	65.75	77.93	86.11
	35	19.70	25.34	31.86	39.34	47.85	57.51	68.52	81.12	89.58
	30	20.89	26.72	33.45	41.15	49.91	59.86	71.20	84.20	92.94
	25	22.06	28.07	35.00	42.91	51.92	62.15	73.82	87.21	96.24
Input Power	65						22.33	22.33	22.36	22.42
	60					19.96	19.97	19.99	20.06	20.14
	55				17.79	17.85	17.89	17.95	18.05	18.14
	50			15.79	15.92	16.01	16.08	16.16	16.28	16.38
	45		13.89	14.13	14.28	14.39	14.48	14.59	14.73	14.84
	40	12.04	12.41	12.67	12.85	12.98	13.08	13.20	13.36	13.49
	35	10.72	11.11	11.38	11.58	11.72	11.84	11.97	12.14	12.28
	30	9.55	9.95	10.24	10.44	10.60	10.73	10.87	11.05	11.18
	25	8.49	8.90	9.20	9.41	9.57	9.71	9.85	10.03	10.17

Notes: Capacity Calculation Based On SH=11.1K,SC=8.3K

7. Application Envelope

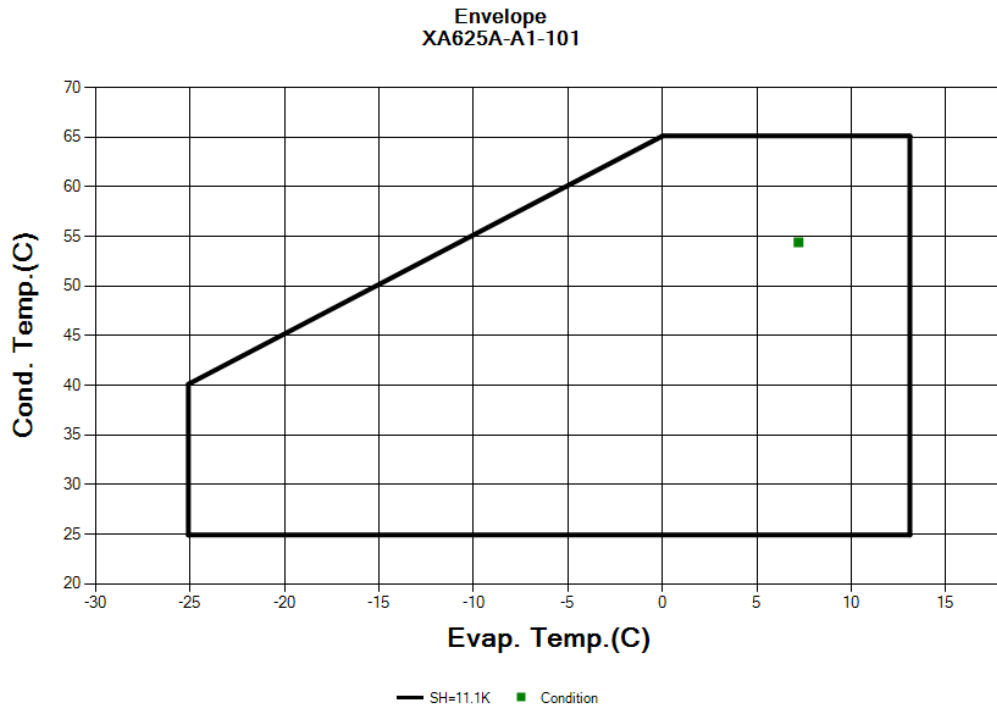

For Compressor Safty, Shutdown Compressor When DLT Above 125°C; When Compressor Running, Control DLT<= 110°C ;ReStart Compressor When DLT Below 85°C

8. Drawing

保 密

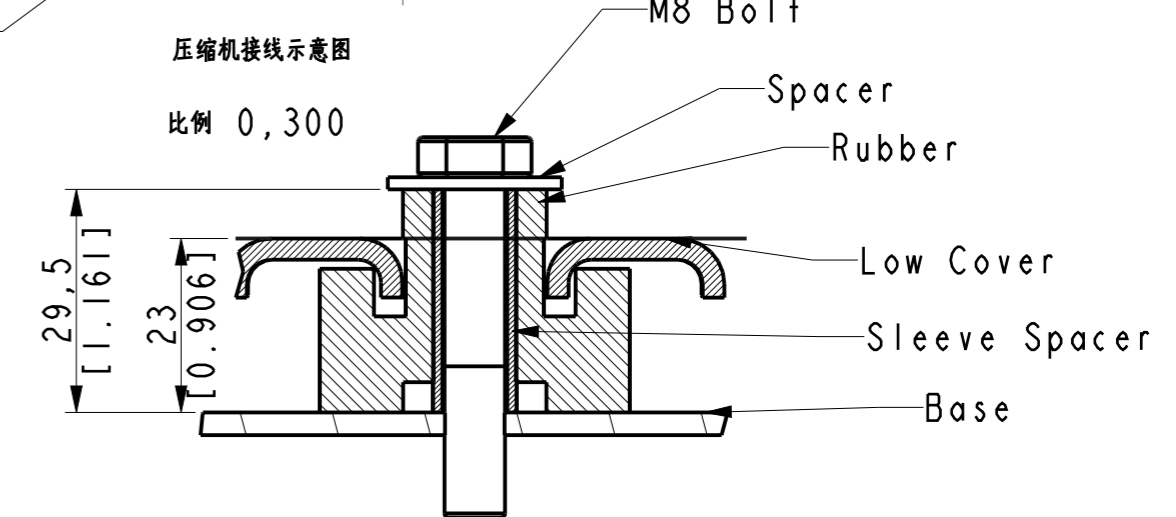
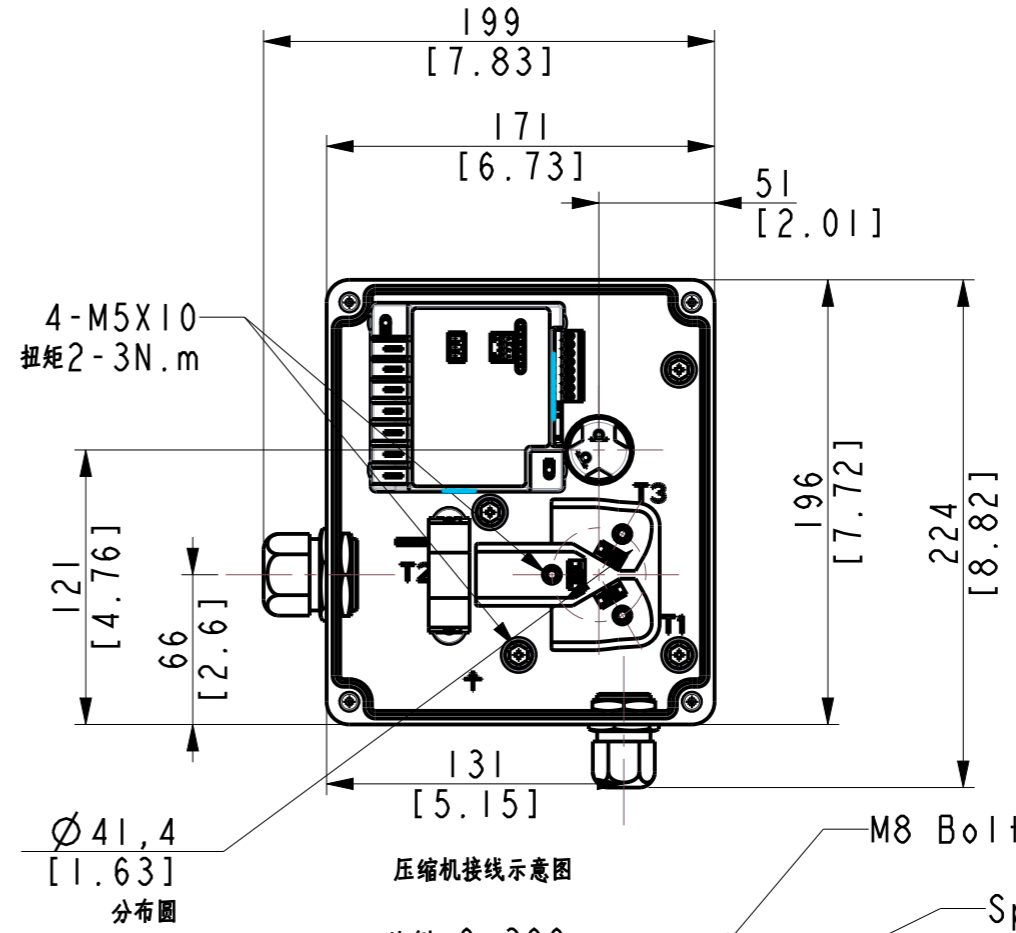
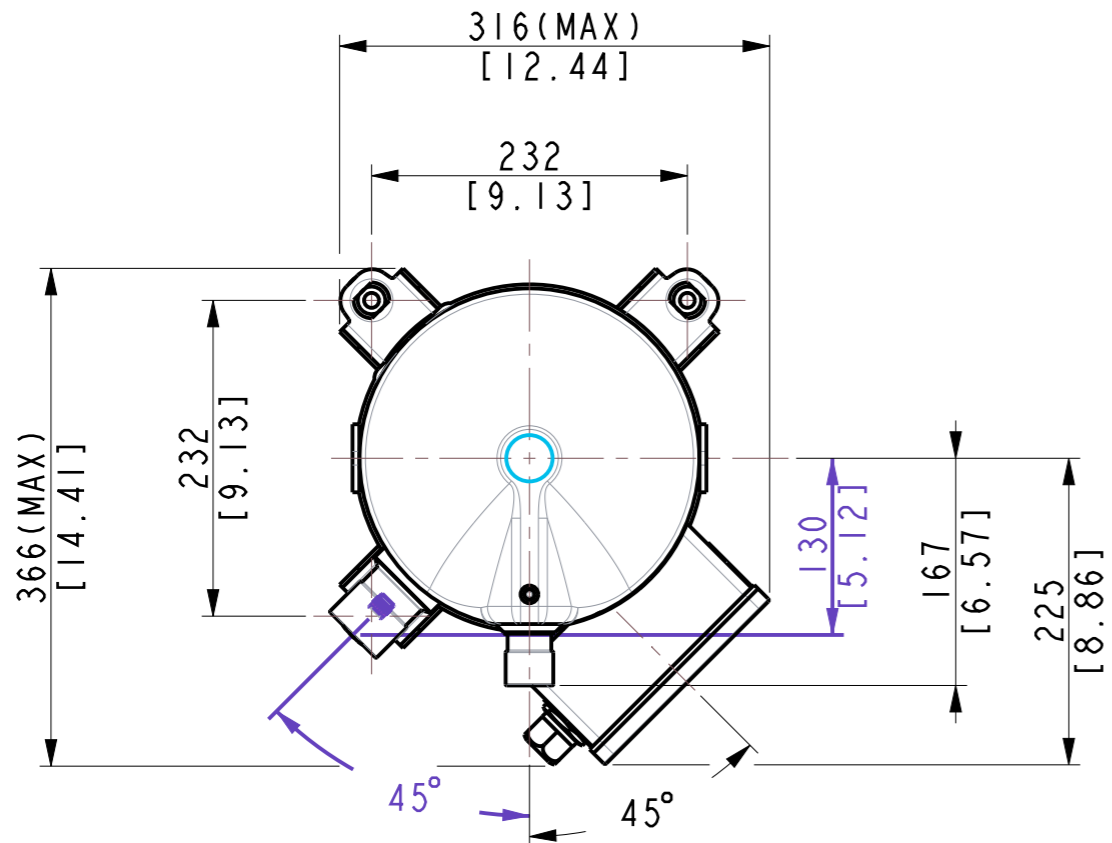

Notes:
 (1) All tolerances $\pm 1.5\text{mm}$ [0.06in] unless otherwise specified
 (2) All fittings: $\pm 3.0\text{mm}$ 0.12in
 (3) Tube ends must be plugged
 (4) All units are in mm/inch]

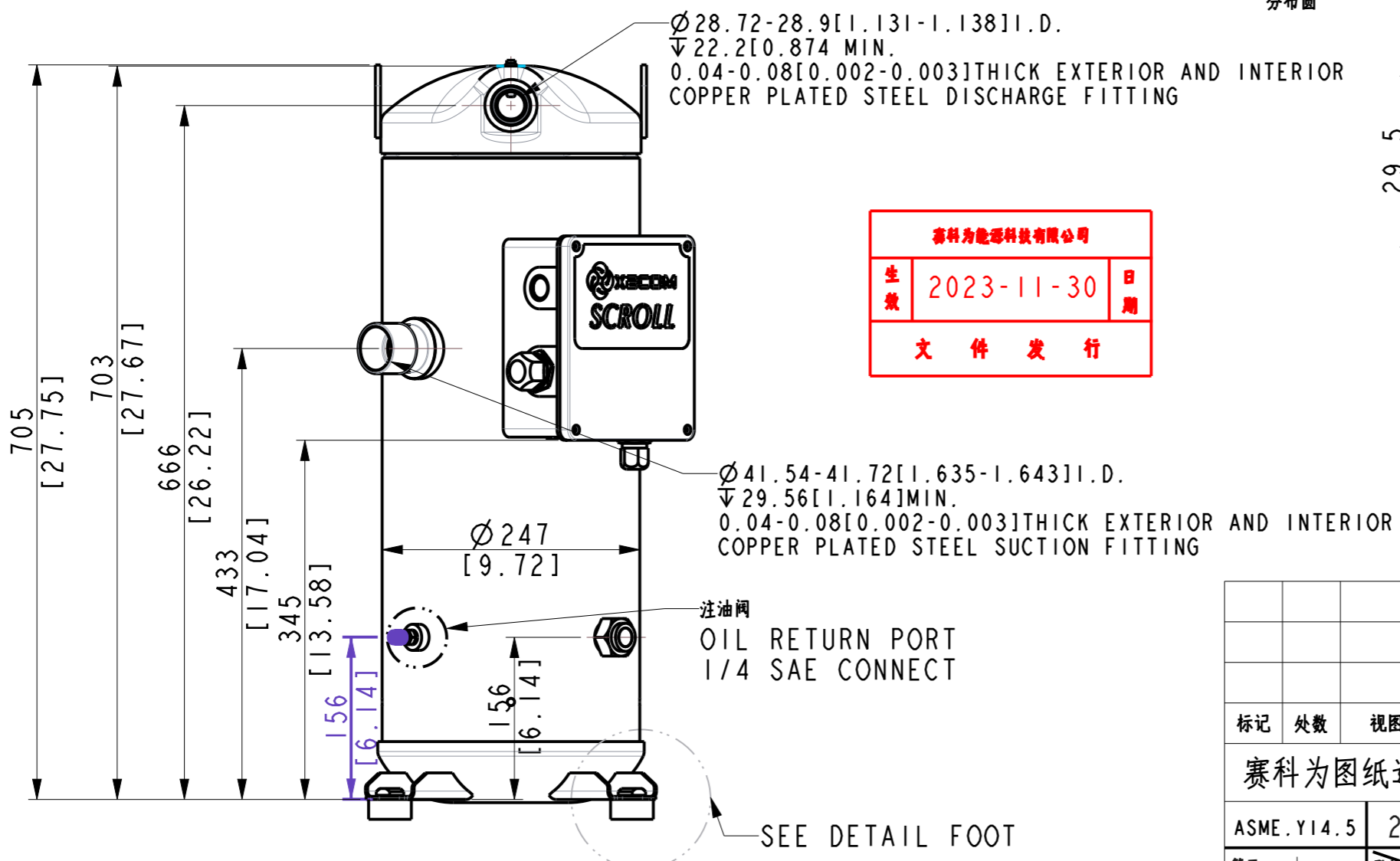

赛科为能源科技有限公司
 生效 2023-11-30 日期
 文件发行

						常州赛科为能源科技有限公司 Xecom Energy Technologies Ltd.			
标记	处数	视图	ECN代码	签字	日期	238外形图 (XR)			
赛科为图纸通用标准						绘图	版本标记	重量	比例
ASME.Y14.5			20°C测量	校对		0		0,180	
第三视角		默认公差	X ± 0.4 Y ± 0.15 Z ± 0.15 AA: ± 0.5	批准		共 1 张 第 1 张			
						801-0006-02EN			

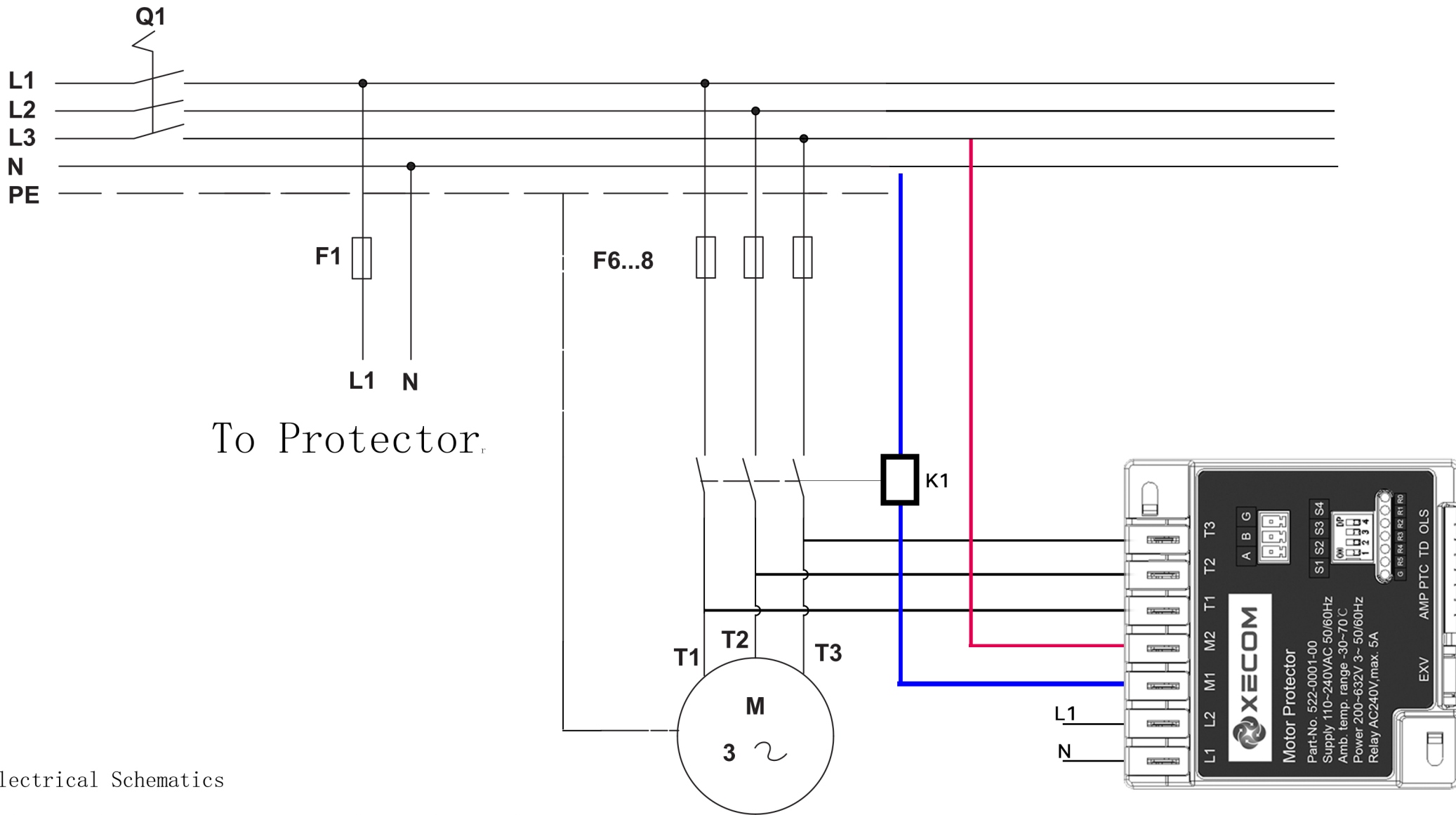

Electrical Schematics

L1/L2/L3/N/PE: 3 Phase Lines (line/neutral/ground)

Q1: Manual Switch

F1/F6...8: Fuse

K1: Compressor Contactor



M: Compressor Motor

T1/T2/T3: Compressor Terminal

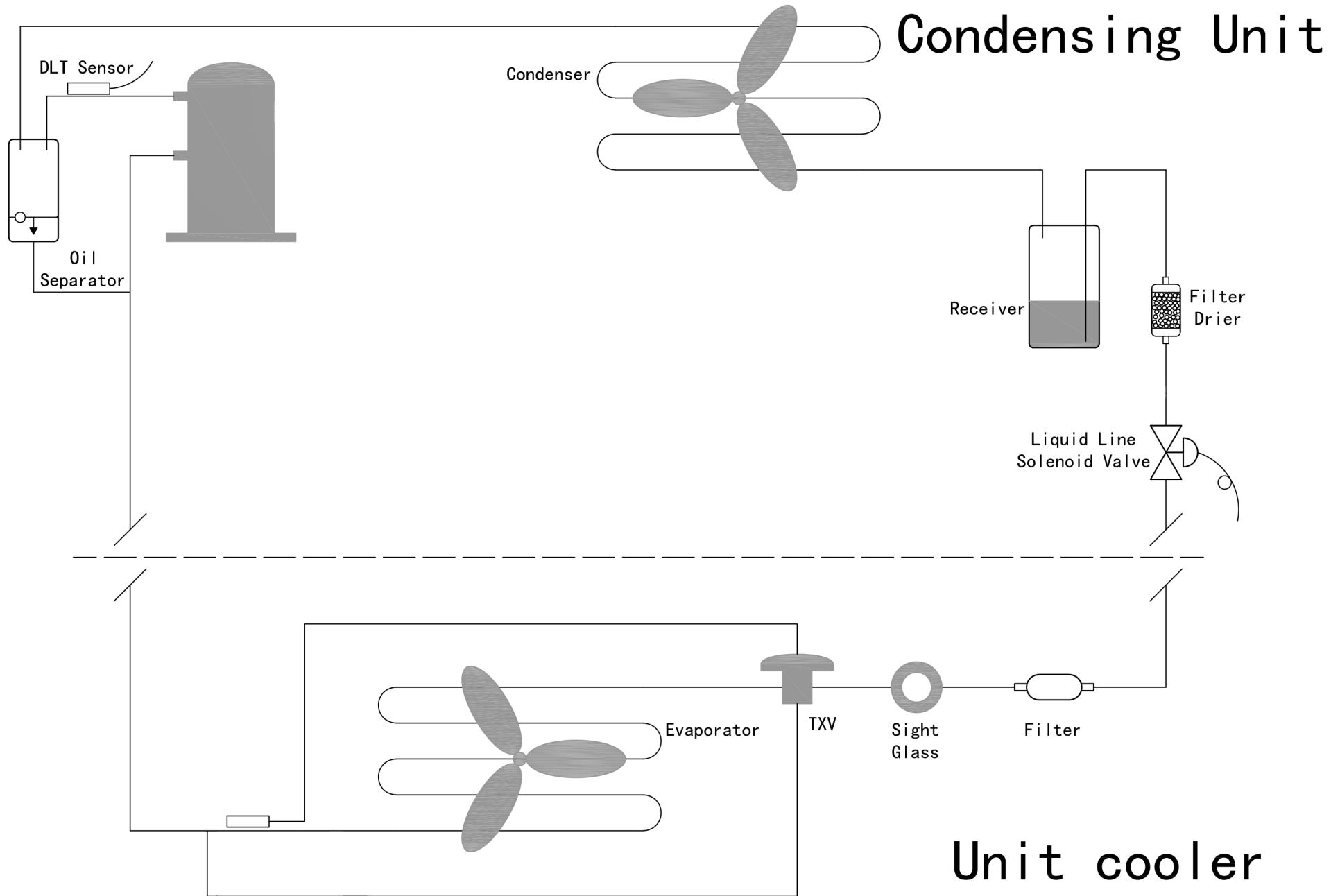

General System Schematic



附件列表
Accessories List

Part N.O.	Specification	Qty	Part Name	Picture	Type	Description
009-0024-00		Ternimal Gasket		1	Standard	
017-0003-00		Ternimal Box		1	Standard	
029-0000-01	M32	Cablegland		1	Standard	





附件列表
Accessories List

029-0000-02	M24*1.5	Cablegland		1	Standard	
009-0036-00		Box Gasket		1	Standard	
017-0004-00		Terminal Cover		1	Standard	
100-0009-00	M4x20	Terminal Cover Bolt		6	Standard	



附件列表
Accessories List

016-0004-00	20.7 分布圆	T-Box		1	Standard	
111-0000-00		Wire For Phase Detect		1	Standard	
111-0000-01		Wire For Phase Detect		1	Standard	
111-0000-02		Wire For Phase Detect		1	Standard	

附件列表
Accessories List

111-0001-00		PTC Wire		2	Standard	
036-0000-00	200A/100mA	Current Transformer		1	Standard	
100-0001-00	M4x10-6g,GB/T 70.1-2000, 12.9 级	Bolt		2	Standard	
112-0002-00	50K	NTC Sensor(50K)		1	Standard	

附件列表
Accessories List

100-0006-01	M5x12,GB/T5789	Bolt		7	Standard	
522-0001-00		External Motor Protector		1	Standard	
019-0002-00	11.1*29.5	Sleeve Spacer		4	Standard	
200-0001-00		Rubber		4	Standard	

附件列表
Accessories List

034-0006-03		Sound Jacket		1	Optional	
028-0004-00	140W,AC220V, 长度 802.6	Crank Heater		1	Optional	
031-0015-00		Oil Adapter		1	Optional	
033-0005-00	OUT580R/GOA114	Oil Regulator		1	Optional	
031-0018-00	1 3/4"-12UNF 2A 螺纹 口	RotoLock Connector		1	Optional	

附件列表
Accessories List

031-0021-00	2 1/4"-12UNF 2A 螺纹 口	RotoLock Connector		1	Optional	
030-0000-00	1-1/4"-12UNF	Sight glasses		1	Standard	
200-0002-00		Steel		4	Optional	

LED Code		Description
G	R5~~~~~R0	
●	●○○○○○	G: Always Flash By 1Secs If Hardware OK R5:Flash Slow: Compressor Stop; R5:Flash Quick: Running Normally
●	○○○○○●	Discharge Temperature Sensor Fail(Open Or Short)
●	○○○○●○	Over Discharge Temperature Trip
●	○○○○●●	Over Discharge Temperature Trip And Lock
●	○○○○●○	Phase Missing Trip
●	○○○○●●	Phase Reverse Trip
●	○○○○●○	Phase Missing Trip And Lock
●	○○○○●●	Phase Reverse Trip Lock
●	○○●○○○	Motor PTC Sensor Fail(Open Or Short)
●	○○●○○○	Motor Temperature Static Trip
●	○○●○○○	Motor Temperature Dynamic Trip
●	○○●○○○	Motor Temperature Trip And Lock
●	○○●●○○	Lack Of Oil Trip
●	○○●●○○	Lack Of Oil Trip And Lock
●	○○●●○○	Over Current Trip
●	○○●●○○	Locked Rotor Trip
●	○○●●○○	Over Current Trip And Lock
●	○○●●○○	Locked Rotor Trip And Lock
●	○○●○○○	Over Liquid Back Alarm
●	○○●○○○	Short Cycling Protection

DIP Switch Configuration

SWITCH CONFIG					
ON		ON		ON	
■	OLS Disabled	■	Protector Mode	■	Td Disable
■	OLS Enabled	■	Controller Mode	■	Td Enable
OFF		OFF		OFF	
1		2		3	

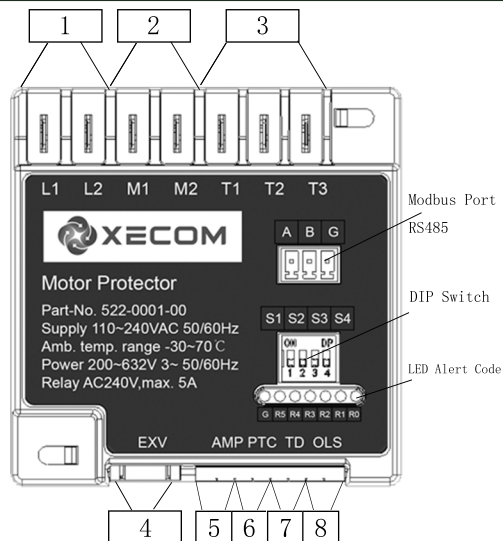
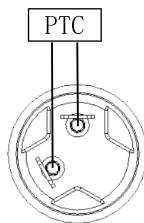

- 1.Power Supply Wire
2. NO Terminal
- 3.Phase Detection Wire
- 4.DLT Control EXV
- 5.Current Sensor
6. Motor PTC Sensor
7. DLT Sensor(50K NTC)
8. Oil Level Sensor

