

XFL35B-D1-105 Technical Specifications

Contents

1 . Specifications.....	1
2 . Configuration.....	1
3 . Attachments.....	2
4 . First Test Condition (°C)	2
5 . Internal Protection Parts.....	2
6. Performance Data	3
7. Application Envelope	4
8. Drawing.....	4

1 . Specifications

Model	XFL35B-D1-105	Power	5HP
Displacement(m³/h)	17.2	Refrigerant	R404A
Cooling Cap.(W) ^(a)	4598	Input Power(W) ^(a)	3524
Rated Load Amps(A) ^(a)	13.7	COP ^(a)	1.30
Max. Vibration(mm) ^(a)	<0.10	Sound Level (dBA) ^(a)	76
Test Power Source ^(a)	60Hz-220V	Rated Speed (RPM) ^(a)	3500
Max. Moisture (mg)	< 500	Max. Impurity (mg)	< 100
Oil Circulation (%) ^(a)	<1%	Weight (kg, With Oil)	28.0
Electrical Specification	Power Source	208V-230V/3Ph/60Hz	
	Run Capacitor	\	
	Min. Operation Voltage(V) ^(b)	187	
	Max. Operation Voltage(V)	253	
	Min. Starting Voltage(V) ^(c)	177	
	Lock Rotor Amps(A)	155.00	
	Max. Operation Current ^(d)	21.5 (A)	
	Motor Insulation Temp.(°C)	130	
Terminal Resistance (Ω) (± 10%) At 25 °C	T1(C)-T2(S)	0.75	
	T2(S)-T3(R)	0.73	
	T3(R)-T1(C)	0.71	
Lubrication	Oil Type	POE(32cSt)	
	Initial Charge(L)	1.4	
	Recharge(L)	1.25	
Electrical Safety	Insulation Voltage(V)	2500	
	Leakage Current(mA)	≤5	
	Insulation Resistance(MΩ)	>20	
	Ground Resistance(Ω)	<0.1	
Max. Operation Pressure	High Side(MPa)	3.2	
	Low Side(MPa)	2.0	

Notes:

- a) Test Condition: Based On Test Power Voltage, First Rated Condition;
- b) Test Condition: ET 0°C, CT 60°C, SH 11.1K
- c) Test Condition: Discharge/Suction Pressure Set To Refrigeration Saturation Pressure At 40°C.
- d) Test Condition: ET 0°C, CT 60°C, SH11.1K, 90% Min. Rated Voltage;

2 . Configuration

Suction/Discharge	Injection	Sight Glass	Thermal Tube
	Liquid		

3 . Attachments

Name	Part Number	Description	Qty.
Screws	100-0006-00	Flange Screw, M5x8,GB/T5789	4
Mount Ground	200-0001-00		4
Mount Sleeve	019-0002-00		4
Terminal Cover	017-0000-00		1
Terminal Fence			NONE
Terminal Cover Seal			NONE
Fusite Seal			NONE
DTC Valve	505-0006-00		1
DTC Seal	009-0015-00	11.5*14.5*1.3	1
Suction Valve Seal	009-0003-00	22*26.5*1.5	1
Discharge Valve Seal	009-0028-00	15.2*18.9*1.7	1

4 . First Test Condition (°C)

Cooling Cap. and COP No Less Than **95%** of Nominal Value, Power and Current No More Than 105% of Nominal Value (Performance And Sound Power Need 24hrs Break In At High Load Running Condition)。

Item	Parameter	Value
1	Evaporating Temp.	-31.7
2	Condensing Temp.	40.6
3	Ambient Temp.	35.0
4	Super Heat	50
5	Sub Cooling	0

5 . Internal Protection Parts

- a) Internal Motor Protector;
- b) Internal Pressure Release Valve, Open Range (Pressure Difference Between Discharge And Suction) : 2.76--3.10Mpa

6. Performance Data

kW	Temp. Cond.(°C)	Temp. Evap. (°C)								
		-40	-35	-30	-25	-20	-15	-10	-5	0
Cooling Cap.	60					4.98	5.95	7.01	8.16	9.36
	55					5.68	6.81	8.07	9.43	10.87
	50	2.72	3.41	4.24	5.21	6.34	7.62	9.05	10.62	12.29
	45	2.95	3.71	4.62	5.70	6.95	8.38	9.98	11.74	13.62
	40	3.17	4.00	5.00	6.17	7.54	9.10	10.86	12.80	14.88
	35	3.39	4.28	5.36	6.63	8.10	9.80	11.71	13.82	16.09
	30	3.61	4.57	5.72	7.08	8.67	10.49	12.54	14.81	17.26
	25	3.84	4.86	6.09	7.54	9.24	11.19	13.38	15.81	18.43
	20	4.09	5.18	6.48	8.03	9.84	11.91	14.24	16.83	
	15	4.36	5.52	6.91	8.56	10.48	12.68	15.16		
Input Power	60					5.65	5.86	6.06	6.22	6.35
	55					5.14	5.34	5.51	5.67	5.79
	50	3.88	4.08	4.28	4.48	4.68	4.86	5.02	5.16	5.28
	45	3.54	3.71	3.89	4.08	4.25	4.42	4.58	4.72	4.83
	40	3.22	3.38	3.54	3.71	3.87	4.03	4.19	4.32	4.44
	35	2.93	3.07	3.22	3.37	3.53	3.69	3.84	3.98	4.11
	30	2.67	2.79	2.92	3.07	3.23	3.39	3.54	3.69	3.83
	25	2.42	2.53	2.66	2.81	2.96	3.13	3.29	3.45	3.61
	20	2.19	2.30	2.43	2.57	2.74	2.91	3.09	3.26	
	15	1.99	2.09	2.22	2.38	2.55	2.73	2.93		

Notes: Capacity Calculation Based On 18.3°C Return Gas And Zero Sub Cooling

7. Application Envelope

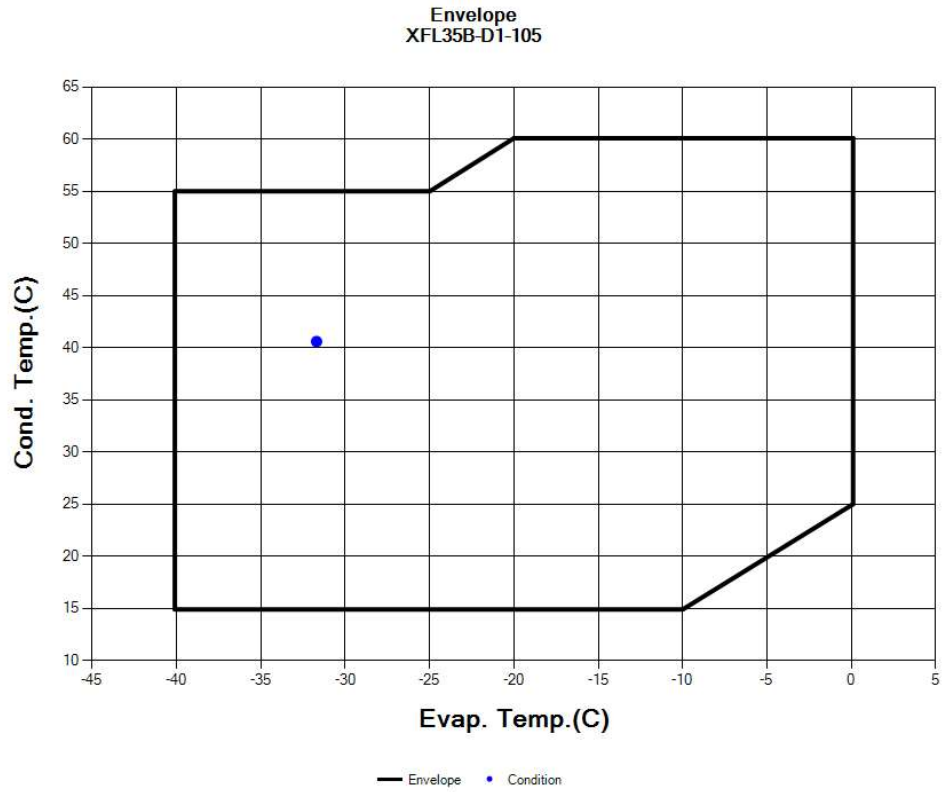

8. Drawing

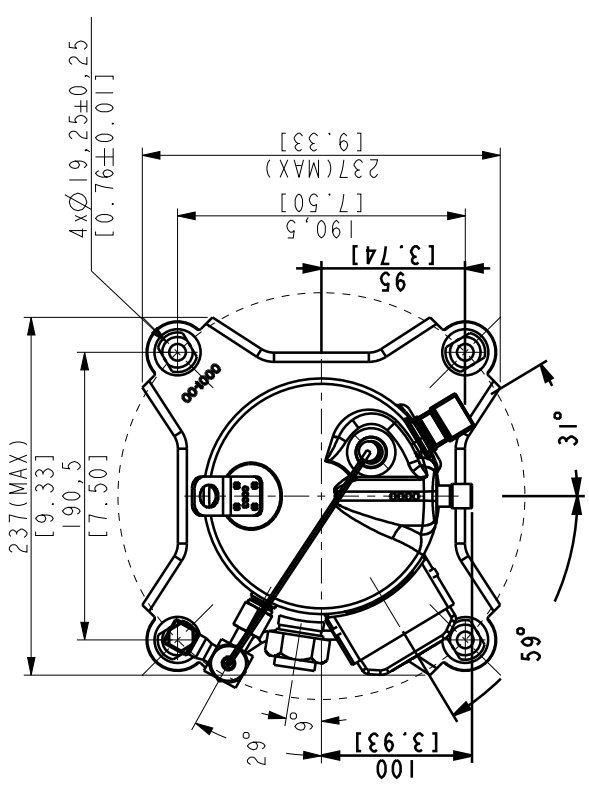

TERMINAL BOX LAYOUT
SCALE 1:2

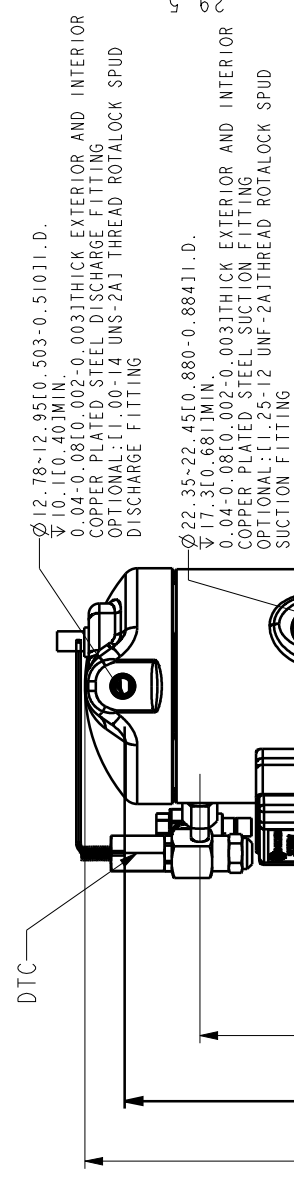

DETAIL FOOT

Notes:

- (1) All tolerances 1.5mm [0.06in] unless otherwise specified
- (2) All fittings: + 3.0mm 0.12in
- (3) Tube ends must be plugged
- (4) All units are in mm/inch

常州赛科为能源科技有限公司 Xecom Energy Technologies Ltd.		150外形图 (XFL)	
1	2	ECN0014	2023/3/28
标记	处数	视图	ECN代码
			签字
			日期
赛科为图纸通用标准		绘图	校对
ASME.Y14.5	20°C 测量	比例	0.125
第三 视图	公差	共 1 张	第 1 张
		重量	
		版本标记	
		比例	
801-0000-04EN			

SEE DETAIL FOOT

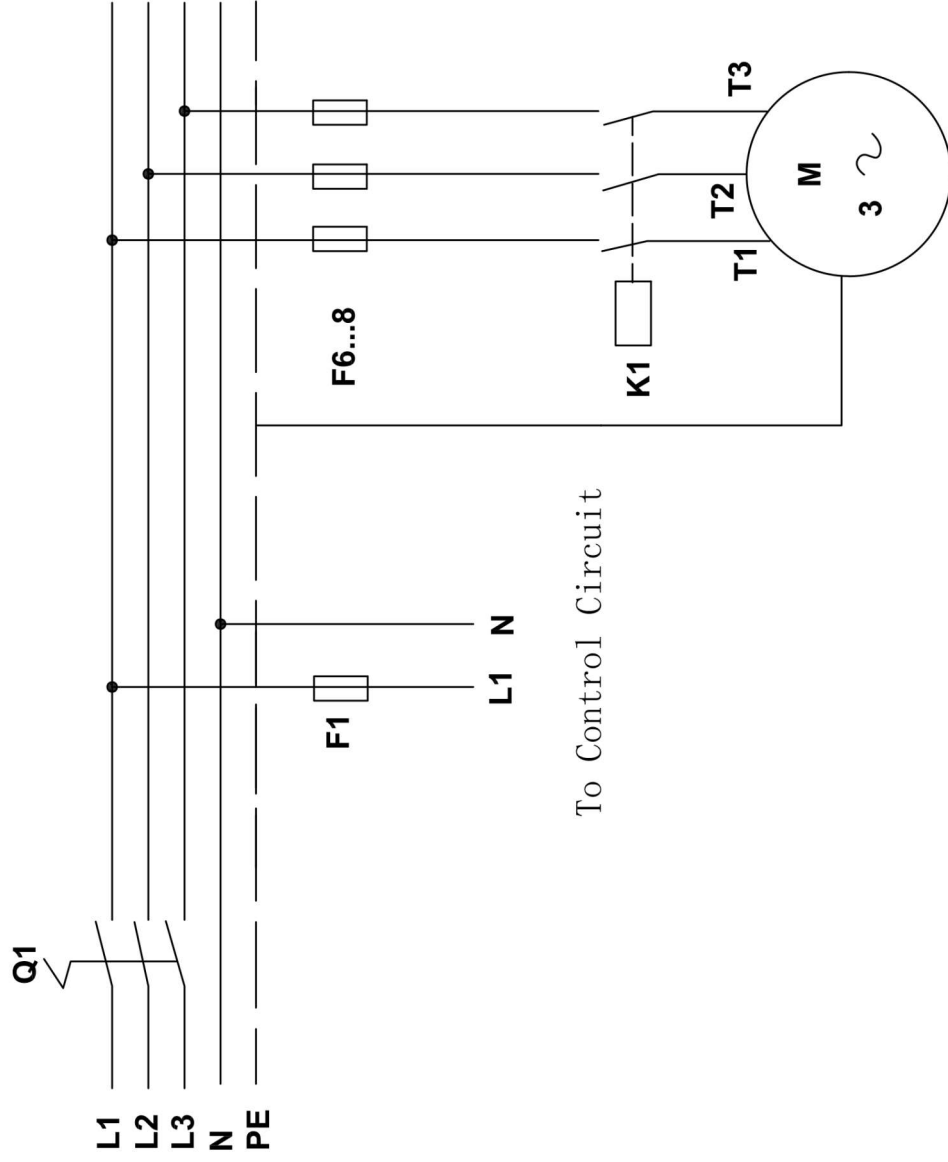

Electrical Schematics

L1/L2/L3/N/PE: 3 Phase Lines (line/neutral/ground)

Q1: Manual Switch

F1/F6...8: Fuse

K1: Compressor Contactor

M: Compressor Motor

T1/T2/T3: Compressor Terminal

Liquid injection schematic

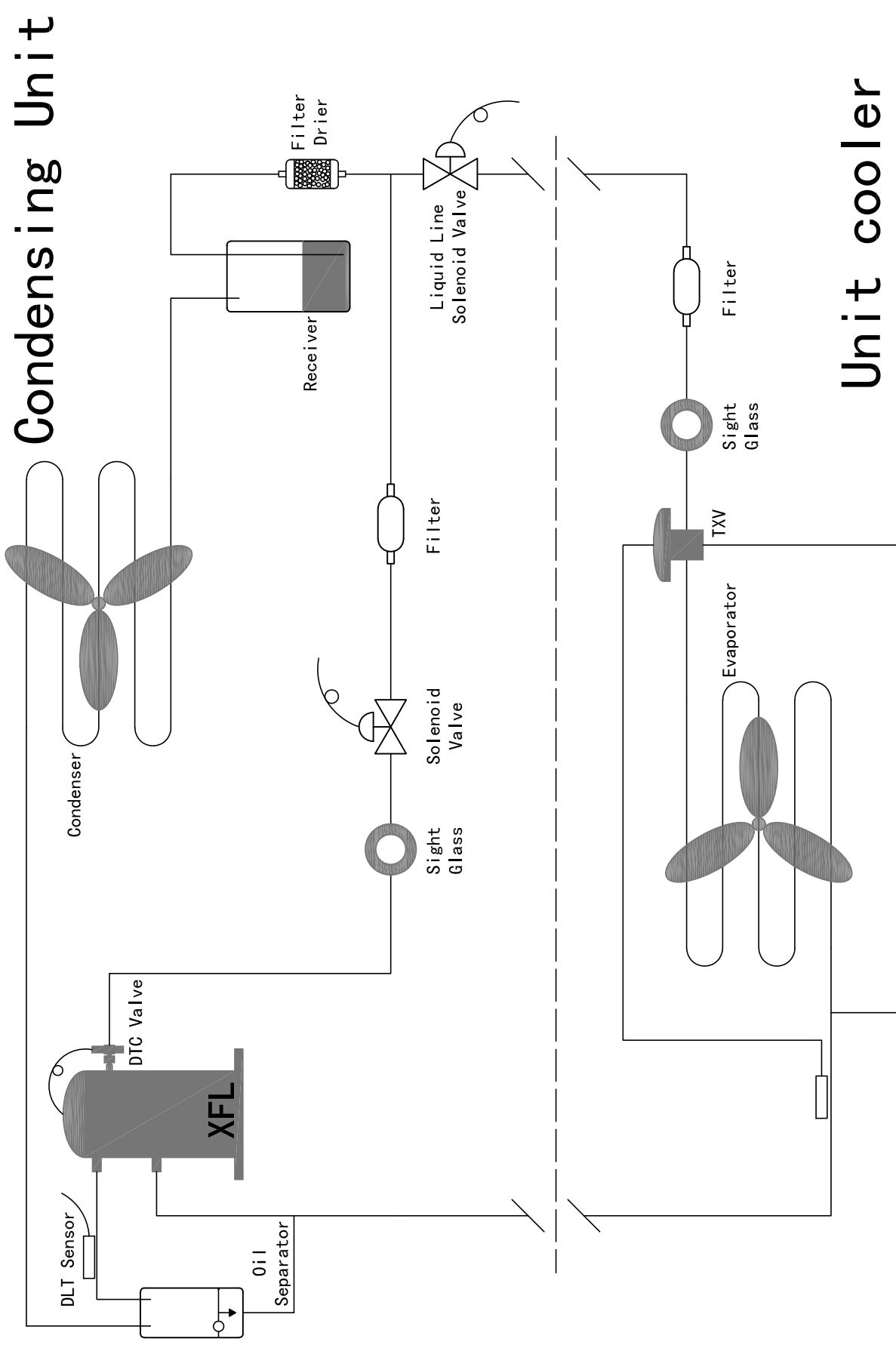

Unit cooler