

# XR52B-C1-101 Technical Specifications

## Contents

1 . Specifications.....	1
2 . Configuration.....	1
3 . Attachments.....	2
4 . First Test Condition (°C) .....	2
5 . Internal Protection Parts.....	2
6. Performance Data .....	3
7. Application Envelope .....	4
8. Drawing.....	5

## 1 . Specifications

Model	XR52B-C1-101	Power	3HP
Displacement(m <sup>3</sup> /h)	10.1	Refrigerant	R404A
Cooling Cap.(W) <sup>(a)</sup>	6265	Input Power(W) <sup>(a)</sup>	3097
Rated Load Amps(A) <sup>(a)</sup>	14.3	COP <sup>(a)</sup>	2.02
Max. Vibration(mm) <sup>(a)</sup>	<0.10	Sound Level (dBA) <sup>(a)</sup>	76
Test Power Source <sup>(a)</sup>	60Hz-220V	Rated Speed (RPM) <sup>(a)</sup>	3500
Max. Moisture (mg)	< 500	Max. Impurity (mg)	< 100
Oil Circulation (%) <sup>(a)</sup>	<1%	Weight (kg, With Oil)	29.0
Electrical Specification	Power Source	208V-230V/1Ph/60Hz	
	Run Capacitor	70uf/450V	
	Min. Operation Voltage(V) <sup>(b)</sup>	187	
	Max. Operation Voltage(V)	253	
	Min. Starting Voltage(V) <sup>(c)</sup>	177	
	Lock Rotor Amps(A)	121.50	
	Max. Operation Current <sup>(d)</sup>	25.1 (A)	
	Motor Insulation Temp.(°C)	130	
Terminal Resistance (Ω) ( ± 10%) At 25 °C	T1(C)-T2(S)	0.60	
	T2(S)-T3(R)	1.88	
	T3(R)-T1(C)	1.28	
Lubrication	Oil Type	POE(32cSt)	
	Initial Charge(L)	1.4	
	Recharge(L)	1.25	
Electrical Safety	Insulation Voltage(V)	2500	
	Leakage Current(mA)	≤5	
	Insulation Resistance(MΩ)	>20	
	Ground Resistance(Ω)	<0.1	
Max. Operation Pressure	High Side(MPa)	3.2	
	Low Side(MPa)	2.0	

Notes:

- a) Test Condition: Based On Test Power Voltage, First Rated Condition;
- b) Test Condition: ET 10°C, CT 65°C, SH 11.1K
- c) Test Condition: Discharge/Suction Pressure Set To Refrigeration Saturation Pressure At 40°C.
- d) Test Condition: ET 10°C, CT 65°C, SH11.1K, 90% Min. Rated Voltage;

## 2 . Configuration

Suction/Discharge	Injection	Sight Glass	Thermal Tube
Welded Fittings	NONE	Screw Sight Glass	NONE

### 3 . Attachments

Name	Part Number	Description	Qty.
Screws	100-0006-00	Flange Screw, M5x8,GB/T5789	4
Mount Ground	200-0001-00		4
Mount Sleeve	019-0002-00		4
Terminal Cover	017-0000-00		1
Terminal Fence			NONE
Terminal Cover Seal			NONE
Fusite Seal			NONE
DTC Valve			NONE
DTC Seal			NONE
Suction Valve Seal			NONE
Discharge Valve Seal			NONE

### 4 . First Test Condition (°C)

Cooling Cap. and COP No Less Than **95%** of Nominal Value, Power and Current No More Than 105% of Nominal Value (Performance And Sound Power Need 24hrs Break In At High Load Running Condition)。

Item	Parameter	Value
1	Evaporating Temp.	-6.7
2	Condensing Temp.	48.9
3	Ambient Temp.	35.0
4	Super Heat	25
5	Sub Cooling	0

### 5 . Internal Protection Parts

- a) Internal Motor Protector;
- b) Internal Pressure Release Valve, Open Range (Pressure Difference Between Discharge And Suction) : 2.76--3.10Mpa

## 6. Performance Data

kW	Temp. Cond.(°C)	Temp. Evap. (°C)								
		-30	-25	-20	-15	-10	-5	0	5	10
Cooling Cap.	65				3.11	3.74	4.48	5.32	6.29	7.43
	60			2.99	3.63	4.37	5.22	6.21	7.35	8.69
	55	2.21	2.75	3.38	4.10	4.93	5.89	7.00	8.29	9.81
	50	2.45	3.05	3.74	4.54	5.46	6.52	7.74	9.18	10.86
	45	2.67	3.32	4.08	4.95	5.95	7.11	8.45	10.02	11.87
	40	2.87	3.58	4.39	5.34	6.42	7.68	9.14	10.84	12.86
	35	3.06	3.81	4.69	5.71	6.88	8.23	9.81	11.66	13.85
	30	3.23	4.04	4.97	6.06	7.32	8.78	10.48	12.47	14.85
	25	3.39	4.25	5.25	6.41	7.76	9.33	11.16	13.32	
	20	3.54	4.45	5.51	6.75	8.20	9.89	11.86		
	15	3.68	4.64	5.77	7.10	8.65	10.46			
10	3.81	4.83	6.04	7.45	9.12					
Input Power	65				3.92	4.08	4.23	4.37	4.50	4.62
	60			3.39	3.54	3.69	3.83	3.97	4.09	4.21
	55	2.77	2.92	3.07	3.22	3.36	3.49	3.62	3.74	3.85
	50	2.53	2.67	2.80	2.94	3.07	3.20	3.32	3.43	3.54
	45	2.32	2.45	2.57	2.70	2.82	2.94	3.06	3.17	3.27
	40	2.13	2.25	2.36	2.48	2.60	2.71	2.82	2.93	3.02
	35	1.96	2.07	2.17	2.28	2.39	2.50	2.60	2.70	2.80
	30	1.80	1.89	1.99	2.09	2.19	2.29	2.39	2.49	2.59
	25	1.63	1.71	1.80	1.89	1.99	2.08	2.18	2.28	
	20	1.44	1.51	1.60	1.68	1.77	1.86	1.96		
	15	1.23	1.30	1.37	1.45	1.53	1.62			
10	0.99	1.05	1.11	1.19	1.27					

Notes: Capacity Calculation Based On 18.3°C Return Gas And Zero Sub Cooling

## 7. Application Envelope

**Envelope  
XR52B-C1-101**

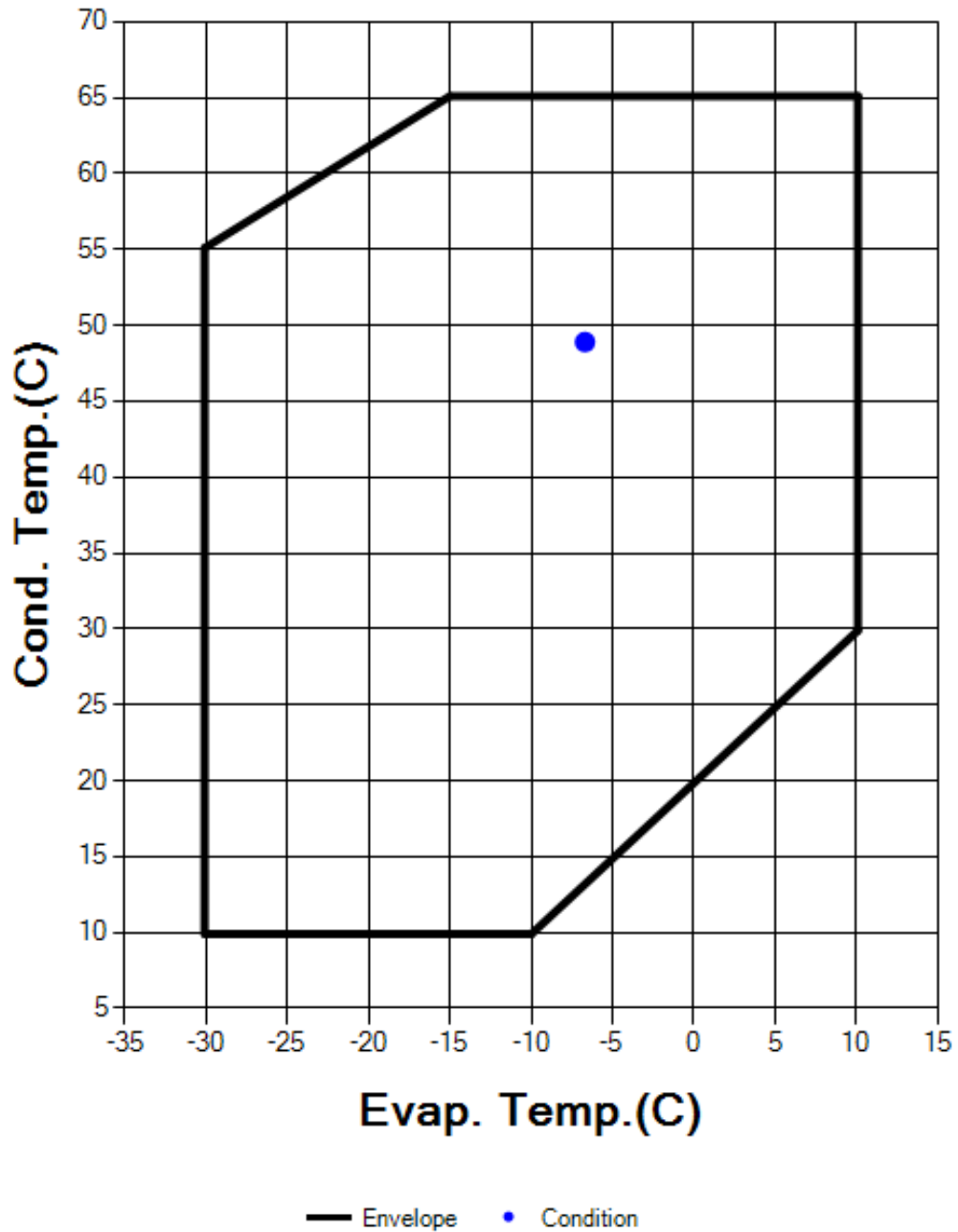

## 8. Drawing

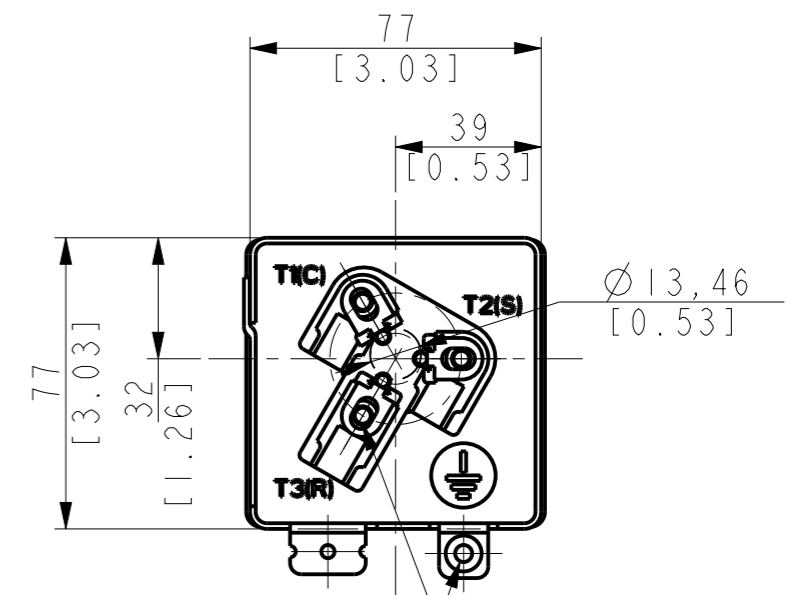
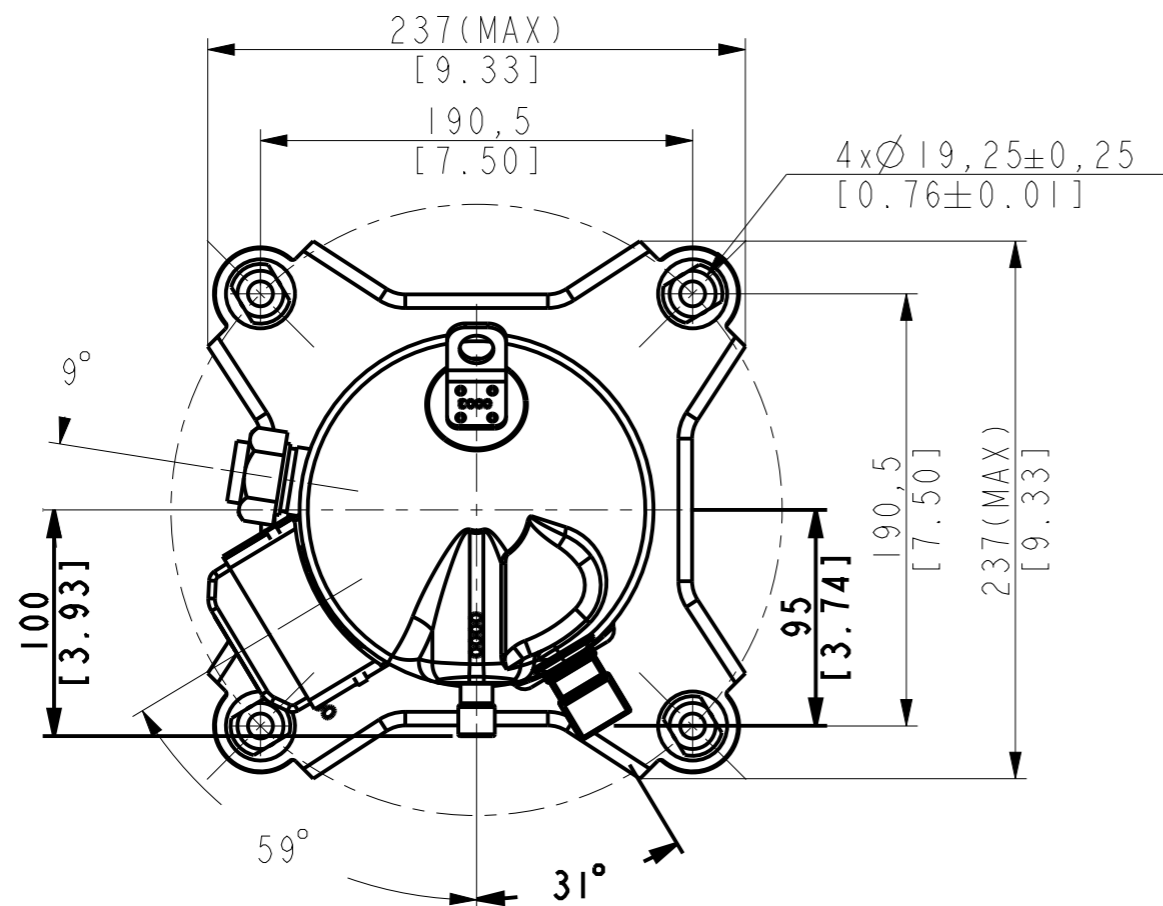

TERMINAL BOX LAYOUT  
SCALE 1:2  
4-M5X10  
TORQUE: 2-3N.m

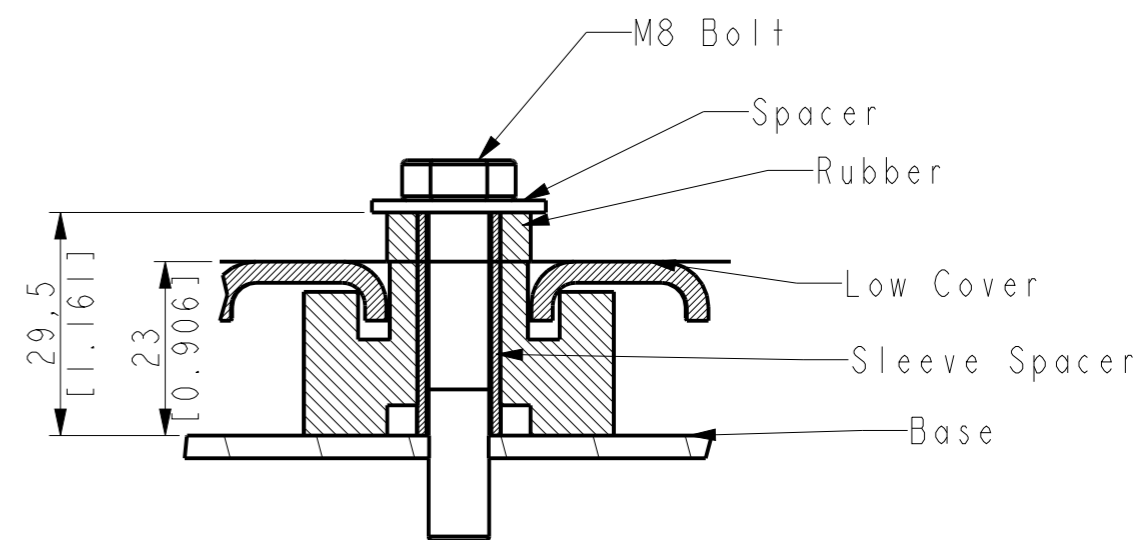

DETAIL FOOT

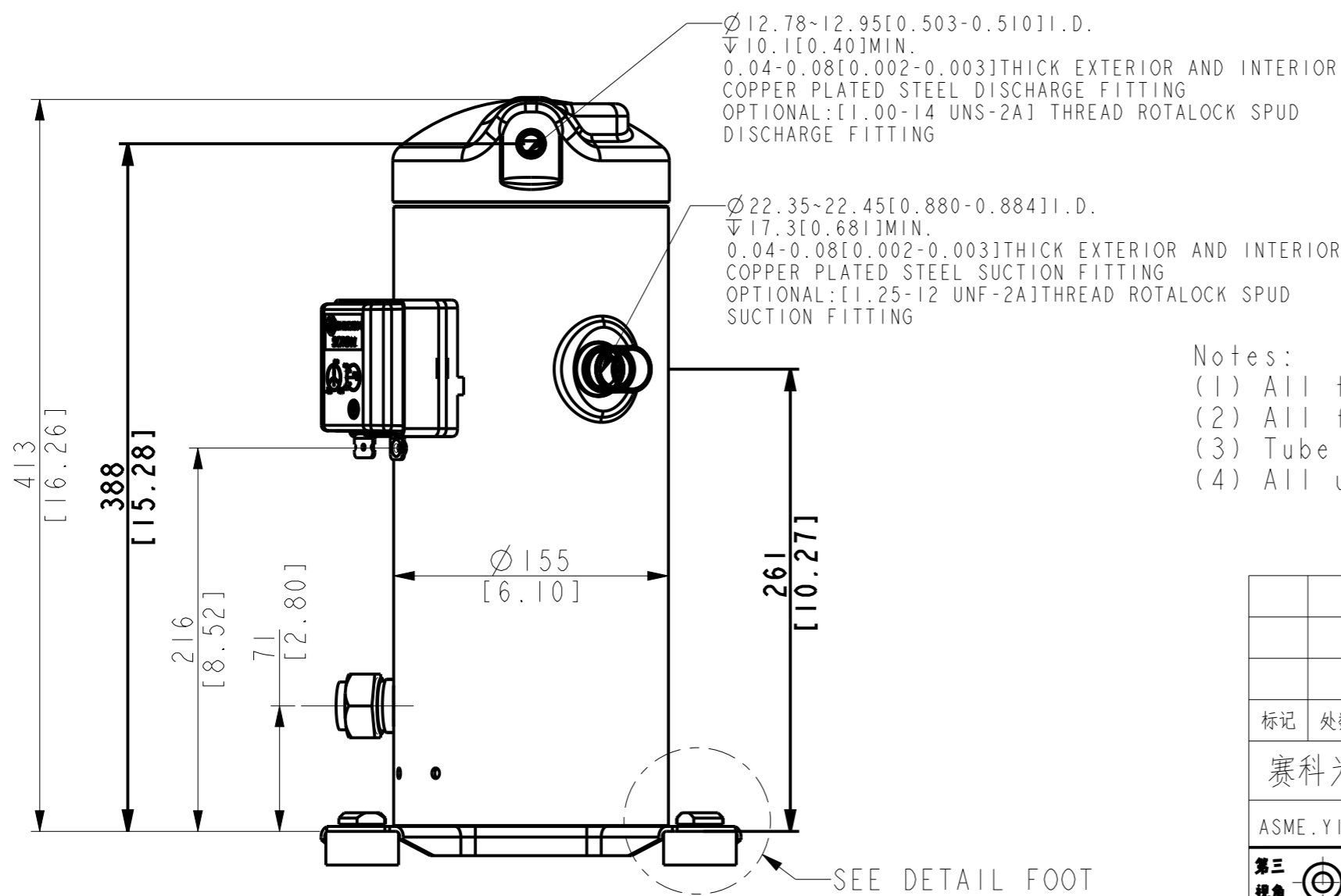

Ø12.78~12.95 [0.503-0.510] I.D.  
▽10.1 [0.40] MIN.  
0.04-0.08 [0.002-0.003] THICK EXTERIOR AND INTERIOR  
COPPER PLATED STEEL DISCHARGE FITTING  
OPTIONAL: [1.00-14 UNS-2A] THREAD ROTALOCK SPUD  
DISCHARGE FITTING

Ø22.35~22.45 [0.880-0.884] I.D.  
▽17.3 [0.68] MIN.  
0.04-0.08 [0.002-0.003] THICK EXTERIOR AND INTERIOR  
COPPER PLATED STEEL SUCTION FITTING  
OPTIONAL: [1.25-12 UNF-2A] THREAD ROTALOCK SPUD  
SUCTION FITTING

- Notes:
- (1) All tolerances 1.5mm [0.06in] unless otherwise specified
  - (2) All fittings: + 3.0mm 0.12in
  - (3) Tube ends must be plugged
  - (4) All units are in mmlinch]

						常州赛科为能源科技有限公司 Xecom Energy Technologies Ltd.		
标记	处数	视图	ECN代码	签字	日期	150外形图 (XR)		
赛科为图纸通用标准				绘图	版本标记	重量	比例	801-0000-02EN
ASME.Y14.5		20°C测量		校对	0	0,125		
第三 视角	默认 公差	X ±0.4 X.X ±0.15 X.XX ±0.15 毫米: ±0.5		批准	共 1 张 第 1 张			

SEE DETAIL FOOT

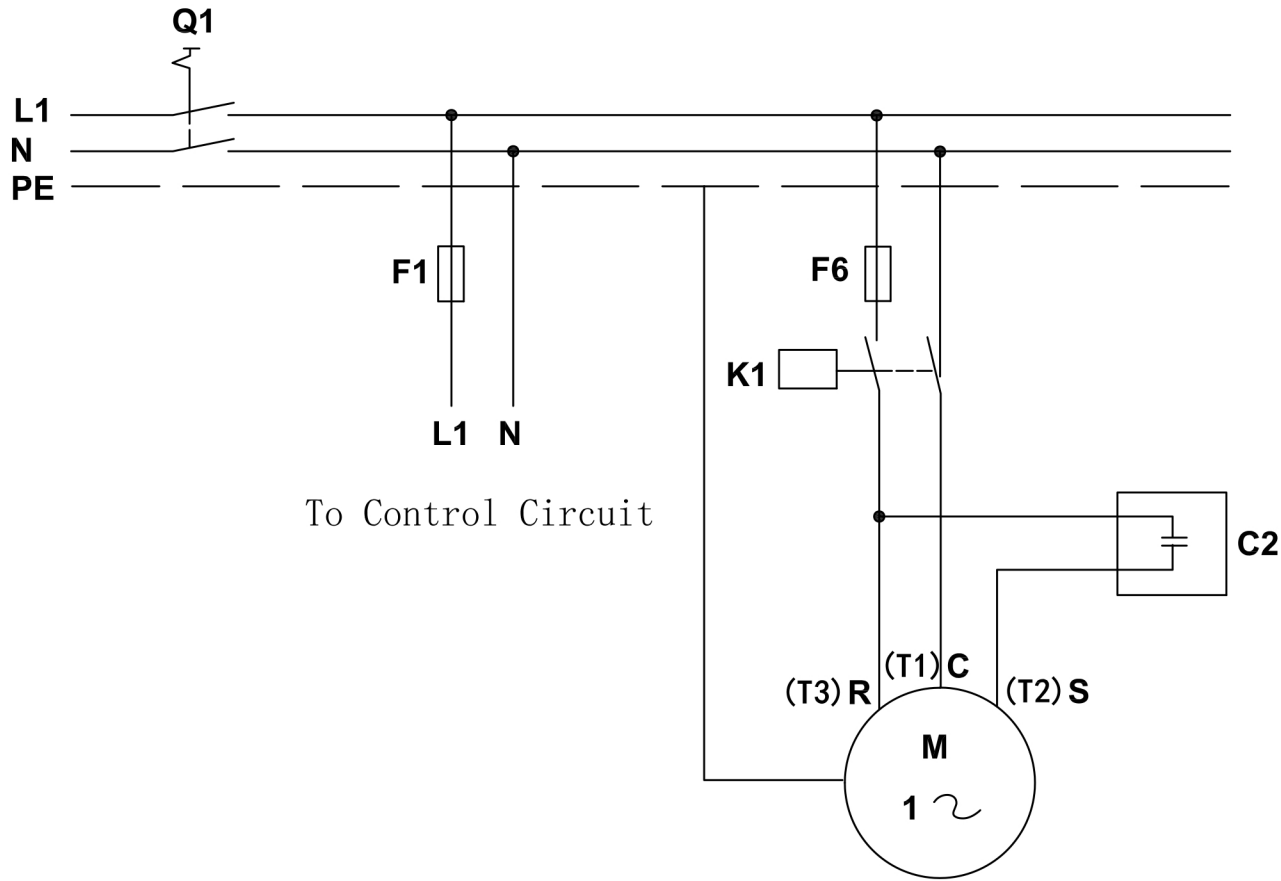

Electrical Schematics

L1/N/PE: Single Phase Lines (line/neutral/ground)

Q1: Manual Switch

F1/F6: Fuse

K1: Compressor Contactor

C2: Run Capacitor

M: Compressor Motor

R/C/S: Compressor Terminal



# General System Schematic

