

# XA150C-A1-101 Technical Specifications

## Contents

1 . Specifications .....	1
2 . Configuration .....	1
3 . Attachments .....	2
4 . First Test Condition (°C) .....	2
5 . Internal Protection Parts .....	2
6. Performance Data .....	3
7. Application Envelope .....	4
8. Drawing .....	4

## 1 . Specifications

Model	XA150C-A1-101	Power	5HP
Displacement(m <sup>3</sup> /h)	10.0	Refrigerant	R410A
Cooling Cap.(W) <sup>(a)</sup>	15110	Input Power(W) <sup>(a)</sup>	4891
Rated Load Amps(A) <sup>(a)</sup>	9.0	COP <sup>(a)</sup>	3.09
Max. Vibration(mm) <sup>(a)</sup>	<0.10	Sound Level (dBA) <sup>(a)</sup>	72
Test Power Source <sup>(a)</sup>	50Hz-380V	Rated Speed (RPM) <sup>(a)</sup>	2900
Max. Moisture (mg)	< 500	Max. Impurity (mg)	< 100
Oil Circulation (%) <sup>(a)</sup>	<1%	Weight (kg, With Oil)	28.0
Electrical Specification	Power Source	380V-420V 3~50Hz 460V 3~60Hz	
	Run Capacitor	/	
	Min. Operation Voltage(V) <sup>(b)</sup>	342	
	Max. Operation Voltage(V)	462	
	Min. Starting Voltage(V) <sup>(c)</sup>	323	
	Lock Rotor Amps(A)	61.00	
	Max. Operation Current <sup>(d)</sup>	13.9 (A)	
	Motor Insulation Temp.(°C)	130	
Terminal Resistance (Ω) ( ± 10%) At 25 °C	T1(C)-T2(S)	3.058	
	T2(S)-T3(R)	3.138	
	T3(R)-T1(C)	3.216	
Lubrication	Oil Type	POE	
	Initial Charge(L)	1.4	
	Recharge(L)	1.25	
Electrical Safety	Insulation Voltage(V)	2500	
	Leakage Current(mA)	≤5	
	Insulation Resistance(MΩ)	>20	
	Ground Resistance(Ω)	<0.1	
Max. Operation Pressure	High Side(MPa)	4.3	
	Low Side(MPa)	2.0	

Notes:

- a) Test Condition: Based On Test Power Voltage, First Rated Condition;
- b) Test Condition: ET 13°C, CT 65°C, SH 11.1K
- c) Test Condition: Discharge/Suction Pressure Set To Refrigeration Saturation Pressure At 40°C.
- d) Test Condition: ET 13°C, CT 65°C, SH11.1K, 90% Min. Rated Voltage;

## 2 . Configuration

Suction/Discharge	Injection	Sight Glass	Thermal Tube
Welded Fittings	NONE	Screw Sight Glass	NONE

## 3 . Certifications

Certifications	Report N.O.
CB	CNCVC0980
CE	LVDJX22-0022
CCC	CVC23008010034
PED	/
UL	/

## 4 . First Test Condition (°C)

Cooling Cap. and COP No Less Than **95%** of Nominal Value, Power and Current No More Than 105% of Nominal Value (Performance And Sound Power Need 24hrs Break In At High Load Running Condition)。

Item	Parameter	Value
1	Evaporating Temp.	7.2
2	Condensing Temp.	54.4
3	Ambient Temp.	35.0
4	Super Heat	11.1
5	Sub Cooling	8.3

## 5 . Compressor Protection Parts

- a) Thermal Protection Inside:3HPD-428;
- b) Internal Pressure Release Valve, Open Range (Pressure Difference Between Discharge And Suction) : 3.96~4.31Mpa

**6. Performance Data- XA150C-A1-101**

kW	Temp. Cond.( °C)	Temp. Evap. (°C)								
		-25	-20	-15	-10	-5	0	5	10	13
Cooling Cap.	65						9.40	11.42	13.79	15.43
	60					8.63	10.53	12.71	15.25	17.03
	55				7.72	9.53	11.54	13.84	16.55	18.46
	50			6.73	8.44	10.33	12.44	14.85	17.72	19.75
	45		5.70	7.31	9.09	11.05	13.24	15.77	18.80	20.95
	40	4.67	6.18	7.85	9.68	11.71	14.00	16.65	19.85	22.14
	35	5.08	6.64	8.36	10.26	12.36	14.75	17.54	20.93	23.39
	30	5.49	7.10	8.88	10.85	13.04	15.54	18.50	22.14	24.78
	25	5.91	7.58	9.44	11.49	13.79	16.45	19.62	23.55	26.43
Input Power	65						6.55	6.47	6.42	6.40
	60					5.81	5.73	5.66	5.62	5.61
	55				5.18	5.10	5.03	4.98	4.95	4.94
	50			4.64	4.56	4.49	4.44	4.41	4.39	4.39
	45		4.18	4.10	4.04	3.99	3.95	3.92	3.91	3.92
	40	3.76	3.69	3.64	3.59	3.55	3.52	3.51	3.51	3.52
	35	3.31	3.27	3.23	3.19	3.17	3.15	3.15	3.16	3.17
	30	2.91	2.88	2.86	2.84	2.83	2.82	2.83	2.84	2.86
	25	2.53	2.52	2.51	2.50	2.50	2.51	2.52	2.54	2.56

Notes: Capacity Calculation Based On SH=11.1K,SC=8.3K

### 7. Application Envelope

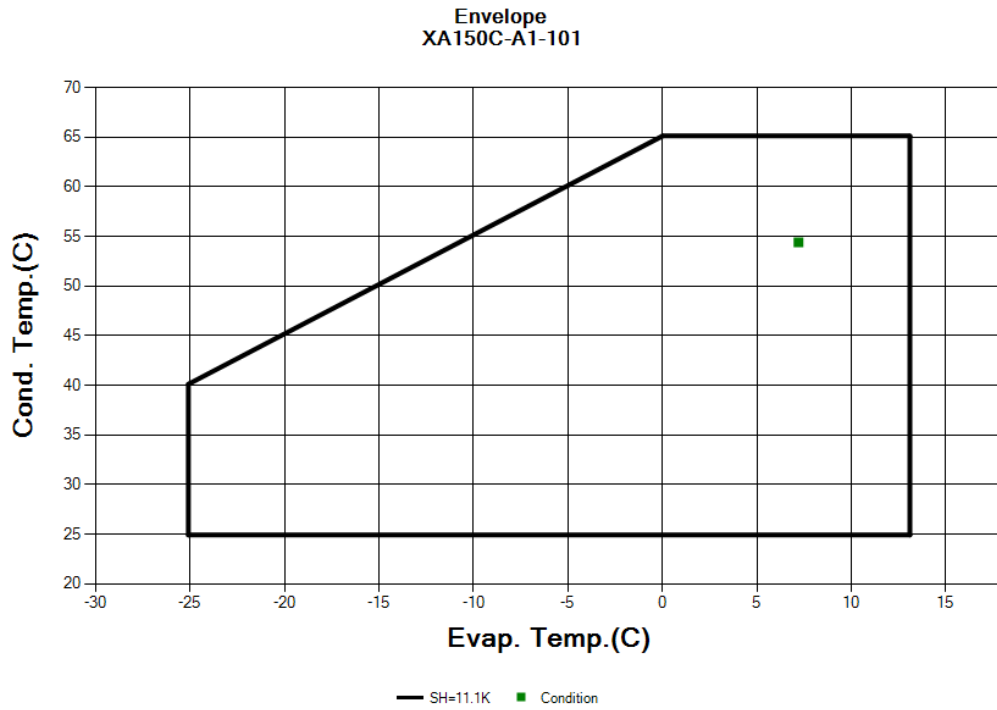

For Compressor Safty, Shutdown Compressor When DLT Above 125°C; When Compressor Running, Control DLT<= 110°C ;ReStart Compressor When DLT Below 85°C

### 8. Drawing



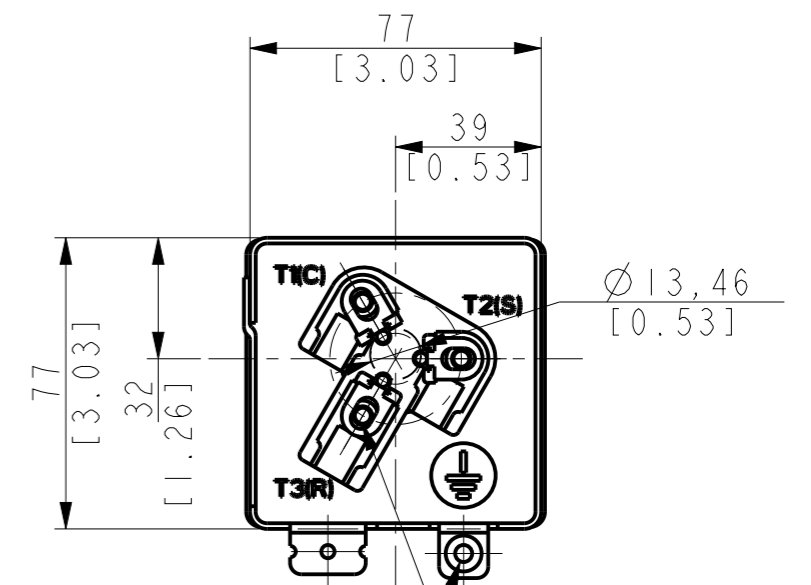
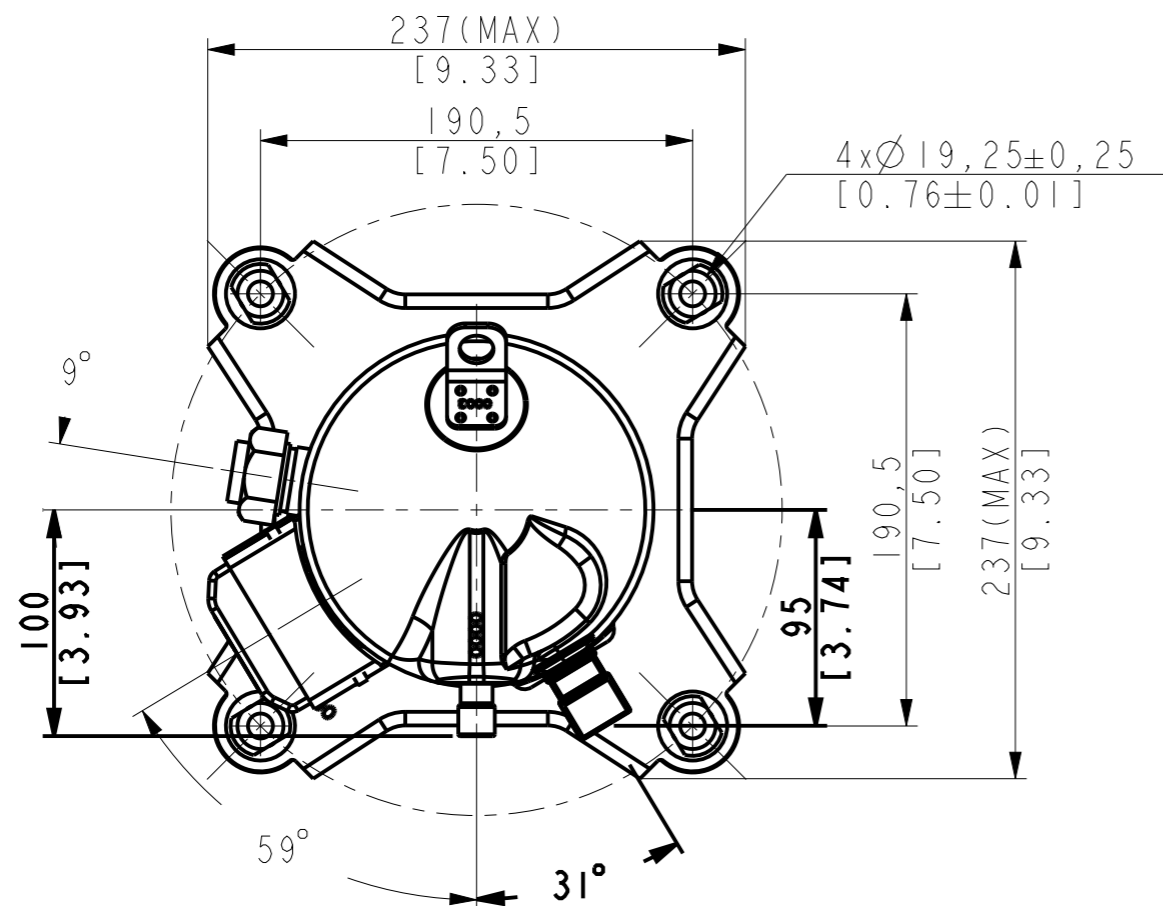

TERMINAL BOX LAYOUT  
SCALE 1:2  
4-M5X10  
TORQUE: 2-3N.m

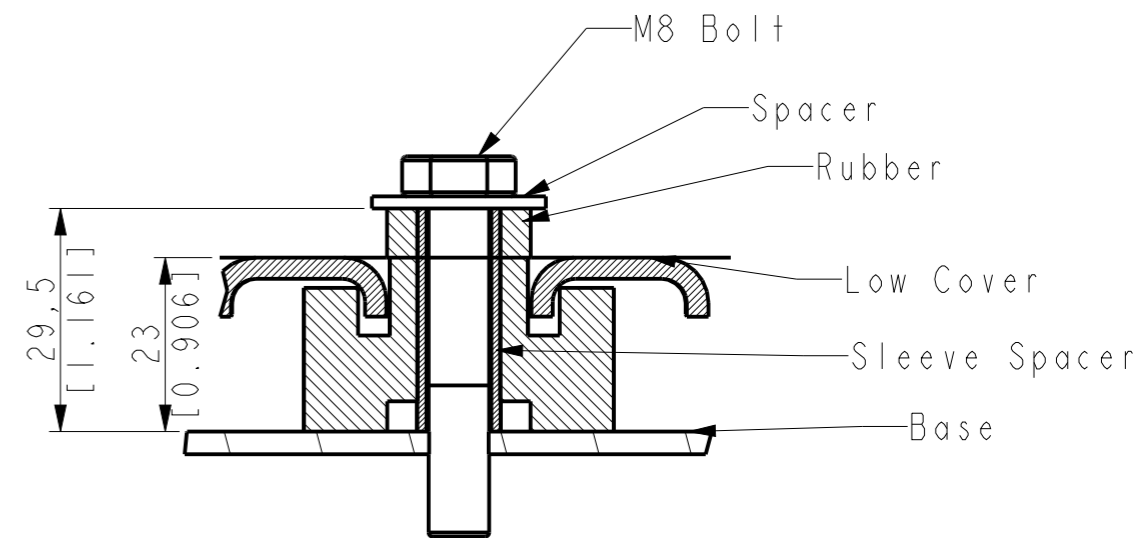

DETAIL FOOT

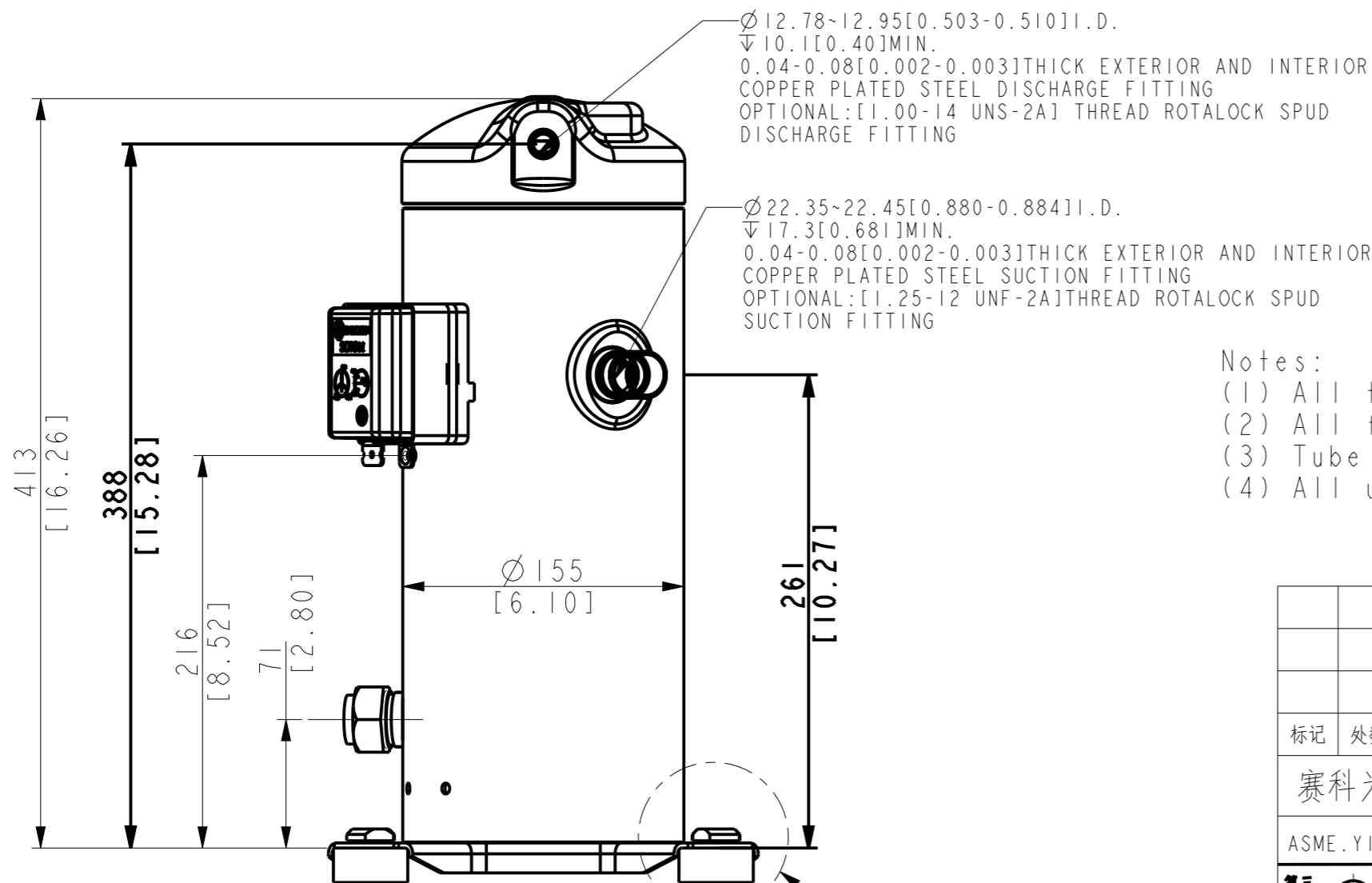

Ø12.78~12.95 [0.503-0.510] I.D.  
▽10.1 [0.40] MIN.  
0.04-0.08 [0.002-0.003] THICK EXTERIOR AND INTERIOR  
COPPER PLATED STEEL DISCHARGE FITTING  
OPTIONAL: [1.00-14 UNS-2A] THREAD ROTALOCK SPUD  
DISCHARGE FITTING

Ø22.35~22.45 [0.880-0.884] I.D.  
▽17.3 [0.68] MIN.  
0.04-0.08 [0.002-0.003] THICK EXTERIOR AND INTERIOR  
COPPER PLATED STEEL SUCTION FITTING  
OPTIONAL: [1.25-12 UNF-2A] THREAD ROTALOCK SPUD  
SUCTION FITTING

Notes:

- (1) All tolerances 1.5mm [0.06in] unless otherwise specified
- (2) All fittings: + 3.0mm 0.12in
- (3) Tube ends must be plugged
- (4) All units are in mmlinch]

						常州赛科为能源科技有限公司 Xecom Energy Technologies Ltd.		
标记	处数	视图	ECN代码	签字	日期	150外形图 (XR)		
赛科为图纸通用标准				绘图	版本标记	重量	比例	
ASME.Y14.5		20°C测量		校对	0	0,125		801-0000-02EN
第三 视角	默认 公差	X ±0.4 X.X ±0.15 X.XX ±0.15 毫米: ±0.5		批准	共   张 第   张			

SEE DETAIL FOOT

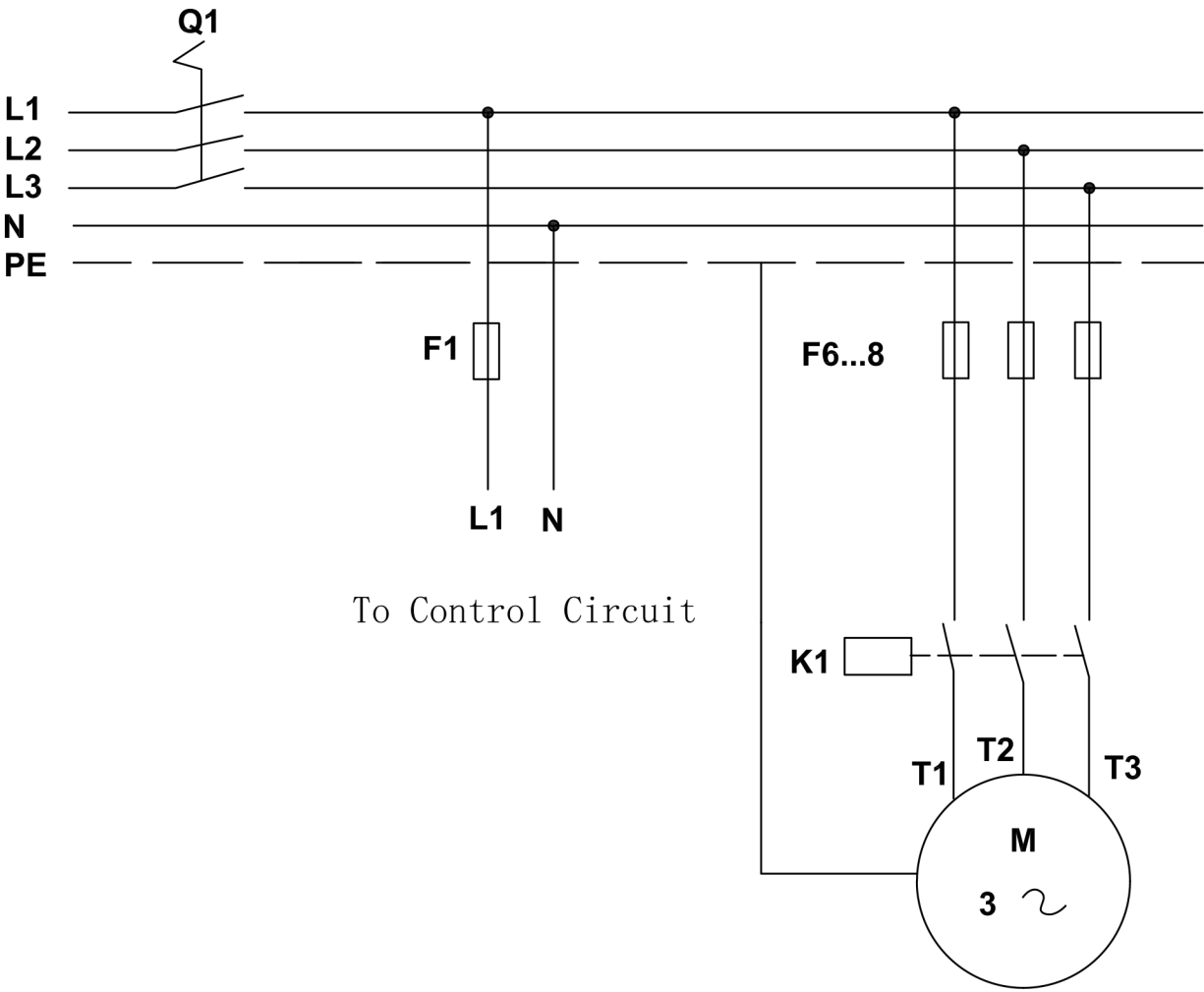

Electrical Schematics

L1/L2/L3/N/PE: 3 Phase Lines(line/neutral/ground)



- Q1: Manual Switch
- F1/F6...8: Fuse
- K1: Compressor Contactor
- M: Compressor Motor
- T1/T2/T3: Compressor Terminal

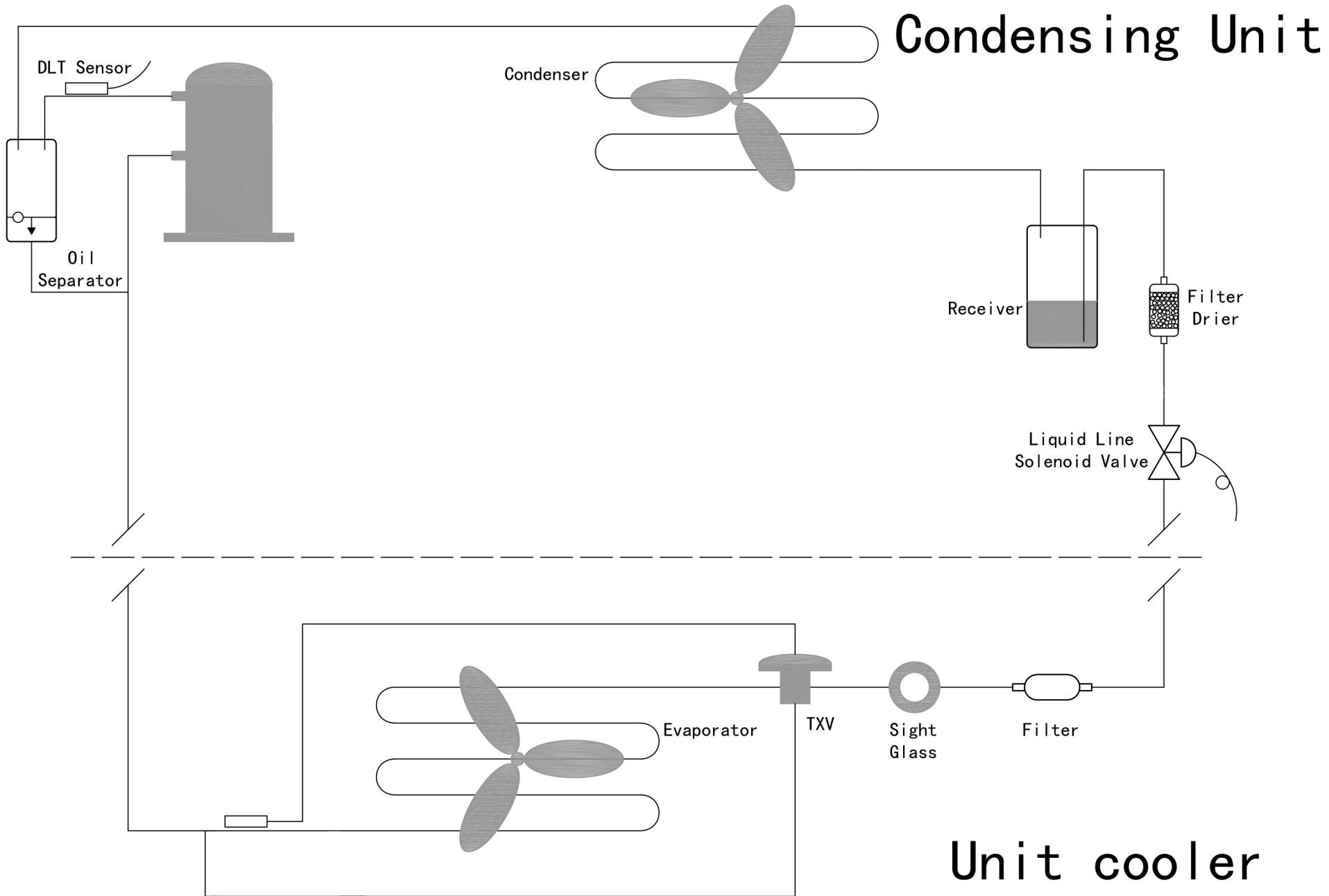

# General System Schematic



附件列表  
Accessories List

Part N.O.	Specification	Qty	Part Name	Picture	Type	Description
020-0001-00		Terminal Seal		1	Standard	 A black square terminal seal with a central white circle. The corners are labeled T1(C), T2(S), T3(R), and T4(L). There is a small white symbol in the bottom-left corner.
019-0002-00	11.1*29.5	Sleeve Spacer		4	Standard	 Two cylindrical metal sleeve spacers of different lengths, one shorter and one longer.
200-0001-00		Rubber		4	Standard	 Two black rubber spacers, one is a simple ring and the other has a central hole.

附件列表  
**Accessories List**

100-0006-00	M5x8,GB/T5789	Bolt		4	Standard	
017-0000-00		Terminal Cover		1	Standard	
016-0001-00		T-Box		1	Standard	
034-0000-03		Sound Jacket		1	Optional	
028-0000-00	155 外径, 70W, 220V, 长度 486, 7	Crank Heater		1	Optional	

附件列表  
**Accessories List**

031-0015-00		Oil Adapter		1	Optional	
033-0005-00	OUT580R/GOA114	Oil Regulator		1	Optional	
031-0019-00	1"-14UN 2A 螺纹口	RotoLock Connector		1	Optional	
031-0017-00	螺纹 1-1/4"-12UNF-A	RotoLock Connector		1	Optional	
030-0000-00	1-1/4"-12UNF	Sight glasses		1	Standard	

附件列表  
**Accessories List**

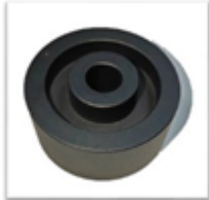
200- 0002-00		Steel		4	Optional	
-----------------	--	-------	--	---	----------	---