

XA120C-C1-100 Technical Specifications

Contents

1 . Specifications.....	1
2 . Configuration.....	1
3 . Attachments.....	2
4 . First Test Condition (°C)	2
5 . Internal Protection Parts.....	2
6. Performance Data	3
7. Application Envelope	4
8. Drawing.....	4

1 . Specifications

Model	XA120C-C1-100	Power	4HP
Displacement(m ³ /h)	9.6	Refrigerant	R410A
Cooling Cap.(W) ^(a)	14419	Input Power(W) ^(a)	4741
Rated Load Amps(A) ^(a)	23.2	COP ^(a)	3.04
Max. Vibration(mm) ^(a)	<0.10	Sound Level (dBA) ^(a)	76
Test Power Source ^(a)	60Hz-220V	Rated Speed (RPM) ^(a)	3500
Max. Moisture (mg)	< 500	Max. Impurity (mg)	< 100
Oil Circulation (%) ^(a)	<1%	Weight (kg, With Oil)	29.5
Electrical Specification	Power Source	208V-230V/1Ph/60Hz	
	Run Capacitor	100uf/500V	
	Min. Operation Voltage(V) ^(b)	187	
	Max. Operation Voltage(V)	253	
	Min. Starting Voltage(V) ^(c)	177	
	Lock Rotor Amps(A)	134.50	
	Max. Operation Current ^(d)	34.8 (A)	
	Motor Insulation Temp.(°C)	130	
Terminal Resistance (Ω) (± 10%) At 25 °C	T1(C)-T2(S)	0.43	
	T2(S)-T3(R)	1.66	
	T3(R)-T1(C)	1.23	
Lubrication	Oil Type	POE(32cSt)	
	Initial Charge(L)	1.4	
	Recharge(L)	1.25	
Electrical Safety	Insulation Voltage(V)	2500	
	Leakage Current(mA)	≤5	
	Insulation Resistance(MΩ)	>20	
	Ground Resistance(Ω)	<0.1	
Max. Operation Pressure	High Side(MPa)	4.3	
	Low Side(MPa)	2.0	

Notes:

- a) Test Condition: Based On Test Power Voltage, First Rated Condition;
- b) Test Condition: ET 13°C, CT 65°C, SH 11.1K
- c) Test Condition: Discharge/Suction Pressure Set To Refrigeration Saturation Pressure At 40°C.
- d) Test Condition: ET 13°C, CT 65°C, SH11.1K, 90% Min. Rated Voltage;

2 . Configuration

Suction/Discharge	Injection	Sight Glass	Thermal Tube
Welded Fittings	NONE	NONE	NONE

3 . Attachments

Name	Part Number	Description	Qty.
Screws	100-0006-00	Flange Screw, M5x8,GB/T5789	4
Mount Ground	200-0001-00		4
Mount Sleeve	019-0002-00		4
Terminal Cover	017-0000-00		1
Terminal Fence			NONE
Terminal Cover Seal			NONE
Fusite Seal			NONE
DTC Valve			NONE
DTC Seal			NONE
Suction Valve Seal			NONE
Discharge Valve Seal			NONE

4 . First Test Condition (°C)

Cooling Cap. and COP No Less Than **95%** of Nominal Value, Power and Current No More Than 105% of Nominal Value (Performance And Sound Power Need 24hrs Break In At High Load Running Condition)。

Item	Parameter	Value
1	Evaporating Temp.	7.2
2	Condensing Temp.	54.4
3	Ambient Temp.	35.0
4	Super Heat	11.1
5	Sub Cooling	8.3

5 . Internal Protection Parts

- a) Internal Motor Protector;
- b) Internal Pressure Release Valve, Open Range (Pressure Difference Between Discharge And Suction) : 3.96—4.31Mpa

6. Performance Data

kW	Temp. Cond.(°C)	Temp. Evap. (°C)								
		-25	-20	-15	-10	-5	0	5	10	13
Cooling Cap.	65						8.97	10.90	13.16	14.73
	60					8.23	10.05	12.12	14.55	16.25
	55				7.37	9.09	11.01	13.21	15.80	17.61
	50			6.42	8.05	9.85	11.87	14.18	16.91	18.84
	45		5.44	6.98	8.67	10.54	12.64	15.05	17.94	20.00
	40	4.46	5.90	7.49	9.24	11.18	13.36	15.89	18.94	21.13
	35	4.85	6.34	7.98	9.79	11.80	14.07	16.73	19.98	22.32
	30	5.23	6.77	8.48	10.35	12.44	14.83	17.65	21.13	23.65
	25	5.64	7.24	9.00	10.96	13.16	15.70	18.72	22.48	25.22
Input Power	65						6.35	6.28	6.22	6.20
	60					5.63	5.55	5.49	5.45	5.44
	55				5.02	4.94	4.87	4.83	4.80	4.79
	50			4.50	4.42	4.36	4.31	4.27	4.25	4.25
	45		4.05	3.98	3.91	3.86	3.82	3.80	3.79	3.80
	40	3.64	3.58	3.53	3.48	3.44	3.41	3.40	3.40	3.41
	35	3.21	3.17	3.13	3.10	3.07	3.06	3.05	3.06	3.07
	30	2.82	2.79	2.77	2.75	2.74	2.73	2.74	2.75	2.77
	25	2.45	2.44	2.43	2.43	2.42	2.43	2.44	2.46	2.48

Notes: Capacity Calculation Based On SH=11.1K,SC=8.3K

7. Application Envelope

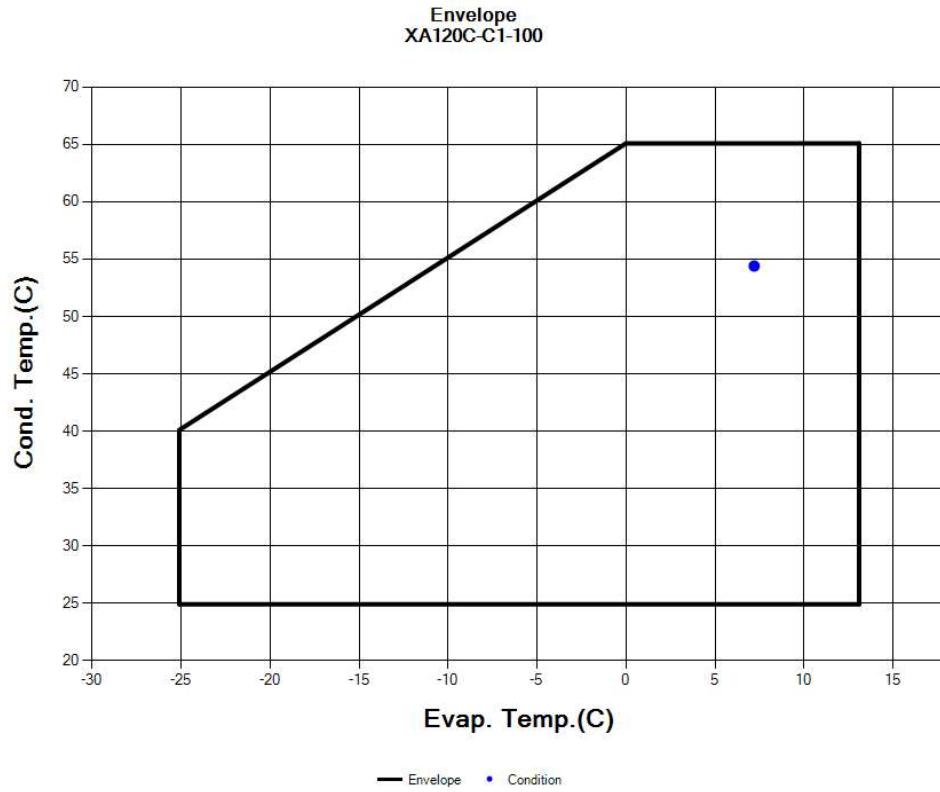

8. Drawing

F E D C B A

2 3 4 5 6 7 8

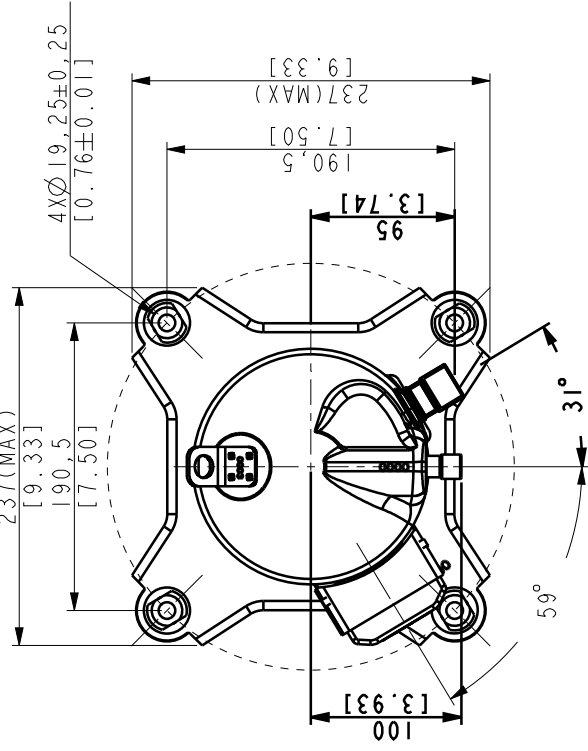

TERMINAL BOX LAYOUT
SCALE 1:2

Ø12.78-12.95 [0.503-0.510] I.D.
▽10.1 [0.40] MIN.
0.04-0.08 [0.002-0.003] THICK EXTERIOR AND INTERIOR
COPPER PLATED STEEL DISCHARGE FITTING

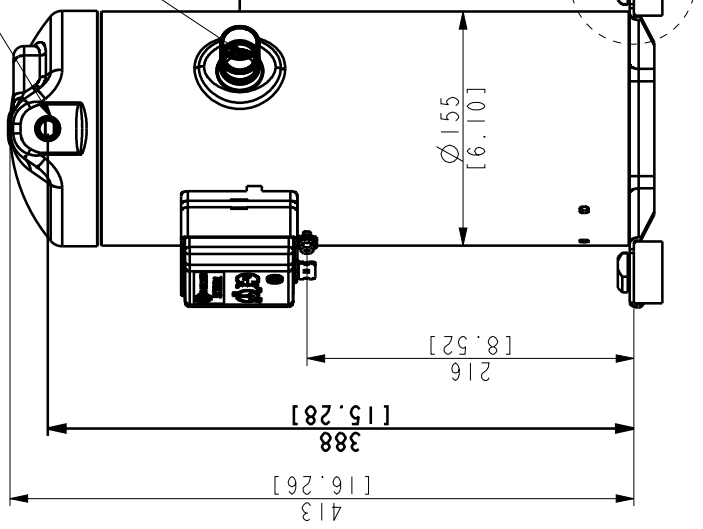

DETAIL FOOT

Notes:
(1) All tolerances 1.5mm [0.06in] unless otherwise specified
(2) All fittings: + 3.0mm 0.12in
(3) Tube ends must be plugged
(4) All units are in mm/inch

常州赛科为能源科技有限公司 Xecom Energy Technologies Ltd.		150外型图 (XA, XW)		比例	
标记	处数	视图	ECN代码	签字	日期
赛科为图纸通用标准			版本标记	重量	比例
ASME: Y14.5	20°C测量	批准	校对	批准	共 1 张 第 1 张
第三	批	批	批	批	批
批	批	批	批	批	批

SEE DETAIL FOOT

F E D C B A

8 7 6 5 4 3 2 1

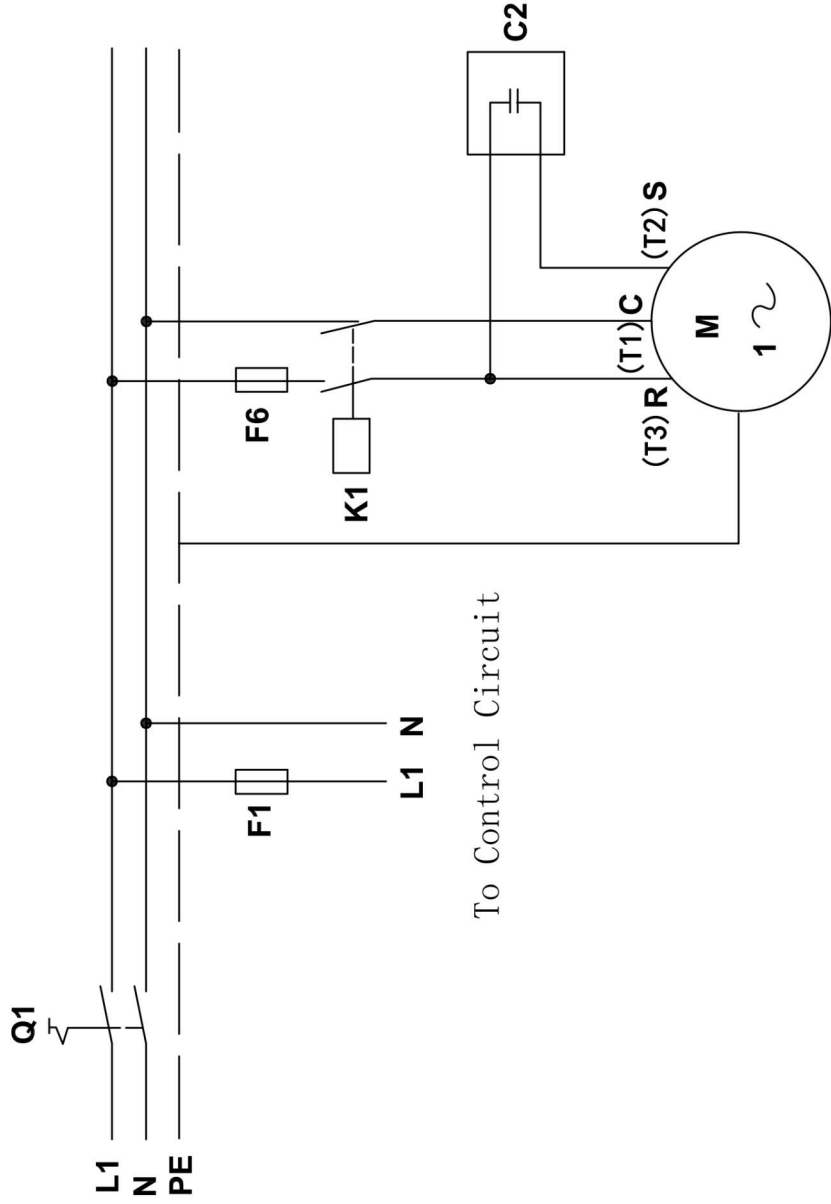

Electrical Schematics

L1/N/PE: Single Phase Lines (line/neutral/ground)

- Q1: Manual Switch
- F1/F6: Fuse
- K1: Compressor Contactor
- C2: Run Capacitor
- M: Compressor Motor
- R/C/S: Compressor Terminal

General System Schematic

